



20 Futbolista



Piezas



Bloque N 3x11 (2)



Bloque N 3x9 (2)



Bloque N 2x11 (2)

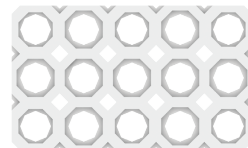

Bloque N 3x5 (1)

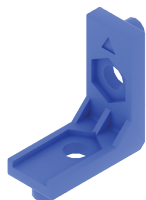

Adaptador L (4)



Bloque N 1x5 (3)



Goma de eje roja/
Red bush (2)



Arandela (12)

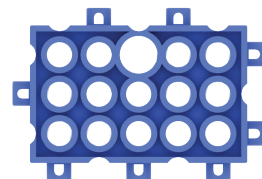

Bloque 3x5 (5)

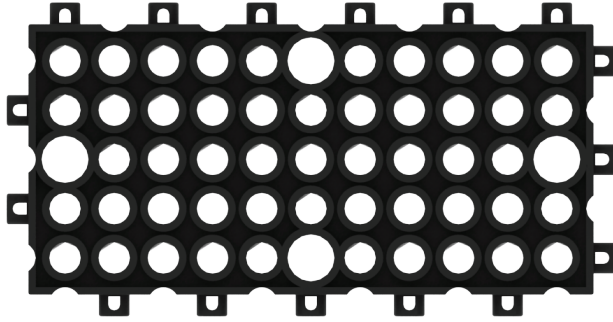

Bloque 5x11 (5)

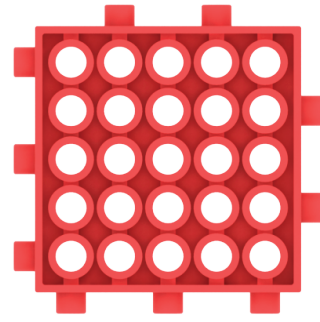

Bloque 5x5 (4)

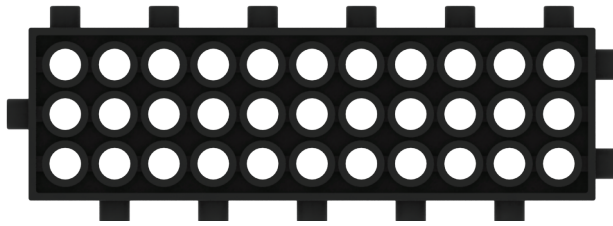

Bloque 3x11 (4)

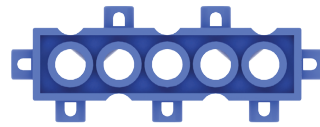

Bloque 1x5 (1)

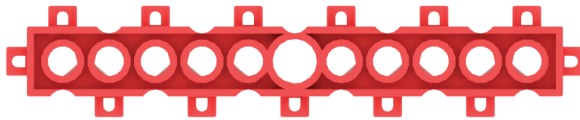

Bloque 1x11 (4)

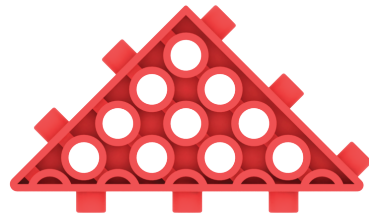

Bloque triangular (4)

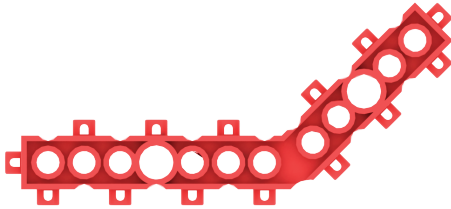

Bloque 135° (6)



Rueda M (2)



Balón de fútbol (1)



Engranaje M (2)



Engranaje L (2)

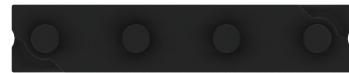

Bloque de unión 2 (2)



Bloque 1x21 (2)

L-shaft Eje L (2)

Motor 2 (2)

R/C sensor (1)

LED Y (1)

Placa base (1)

Cable de conexión (3)

Alargador de cable (2)

Portapilas o portabaterías 1 (1)

Portapilas o portabaterías 2 (2)

01

02

03

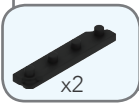
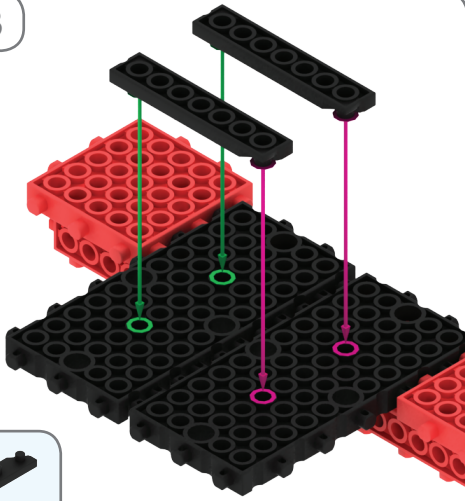

04

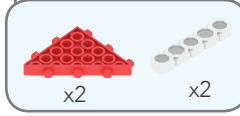
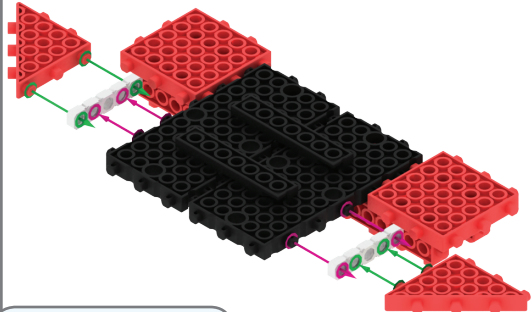

05

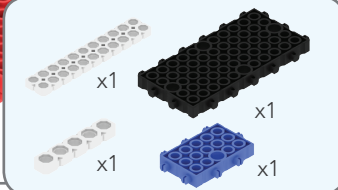
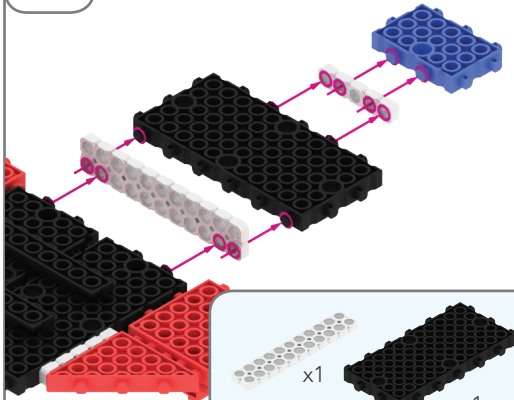

06

Nota: el triángulo rojo ▲ señala la posición.

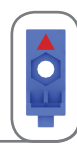
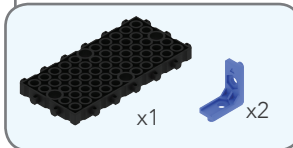
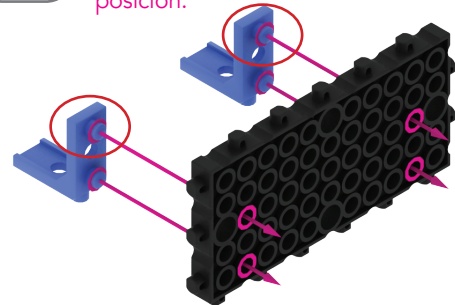

07

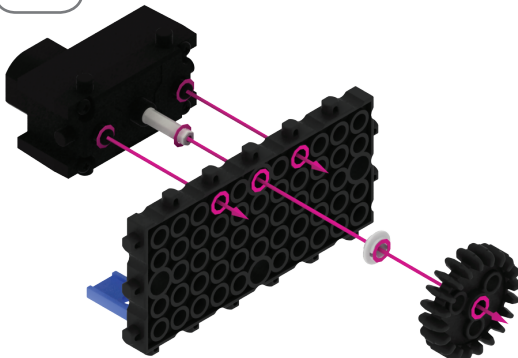

08

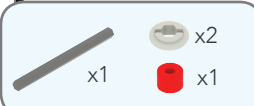
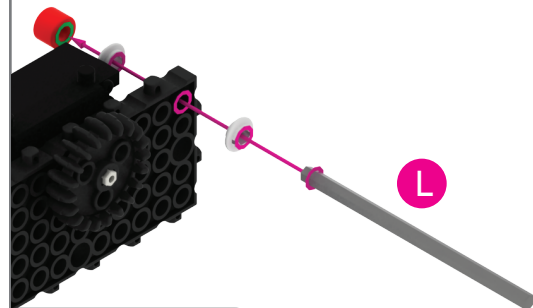

1:1

09

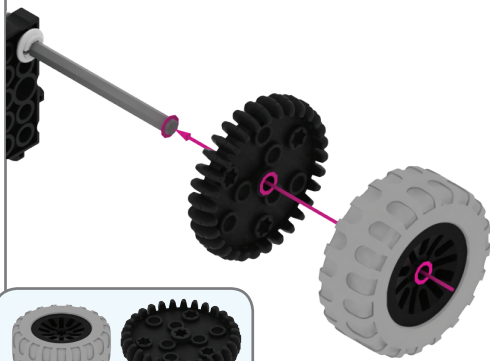

10

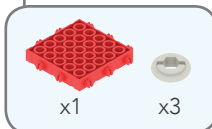
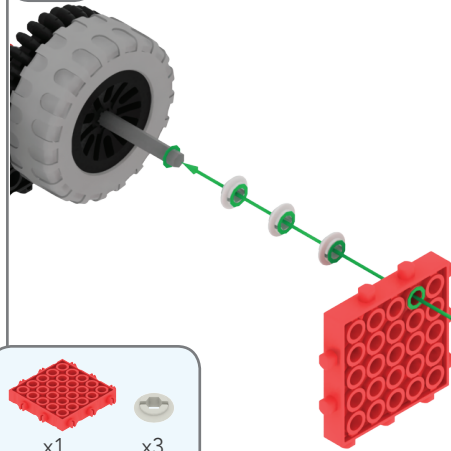

11

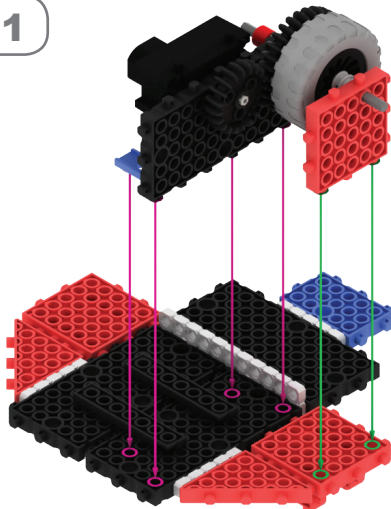

12

Nota: el triángulo rojo ▲ señala la posición.

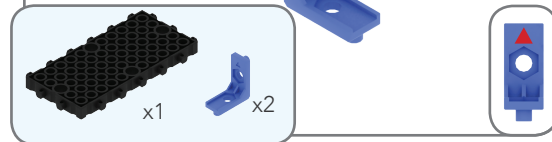
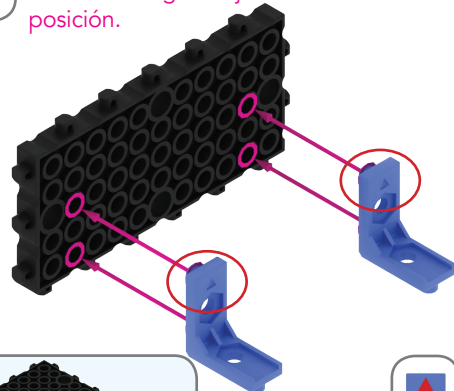

13

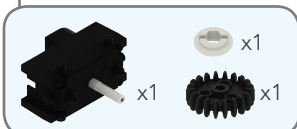
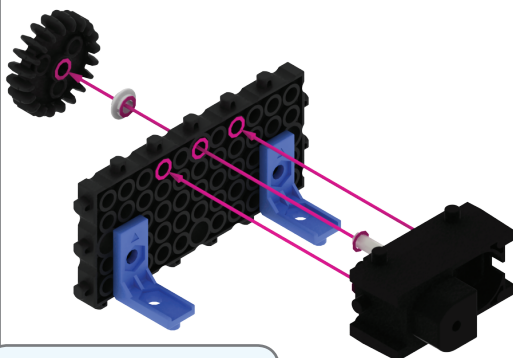

14

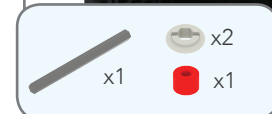
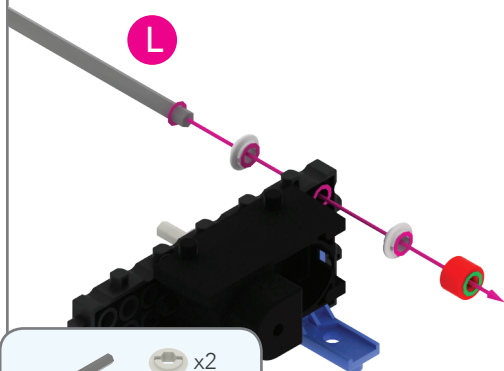

1:1

15

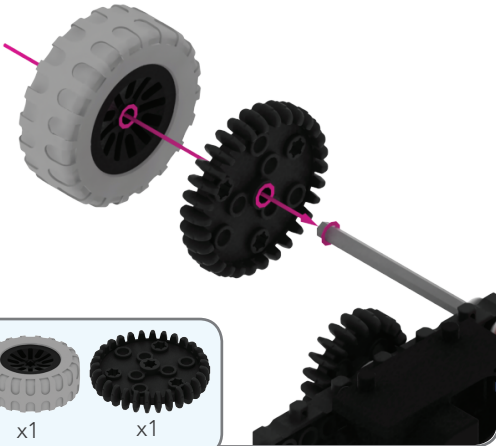

16

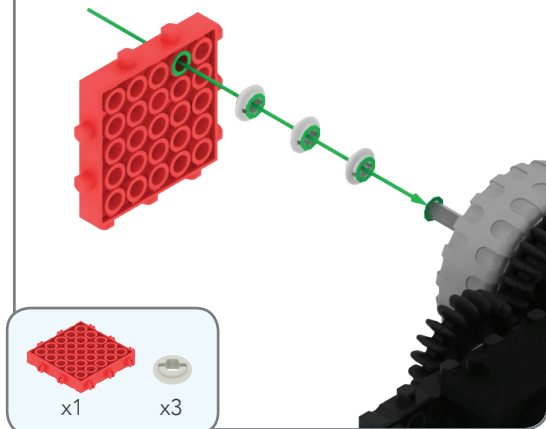

17

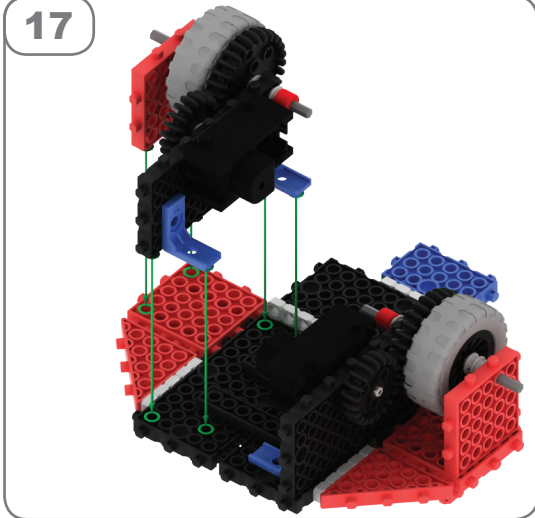

18

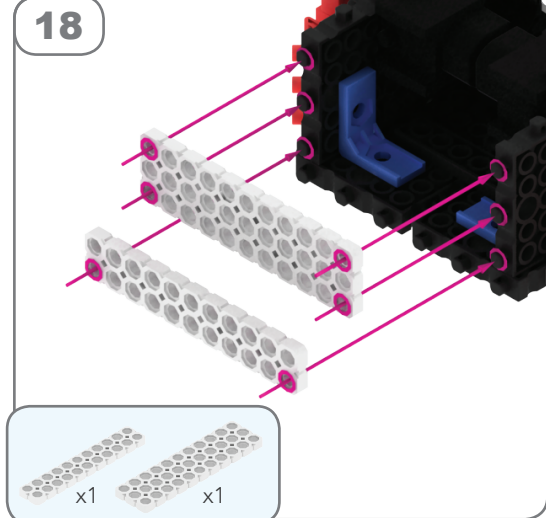

19

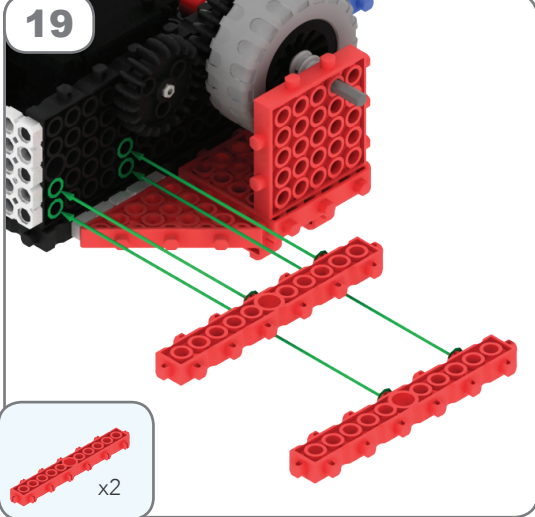

20

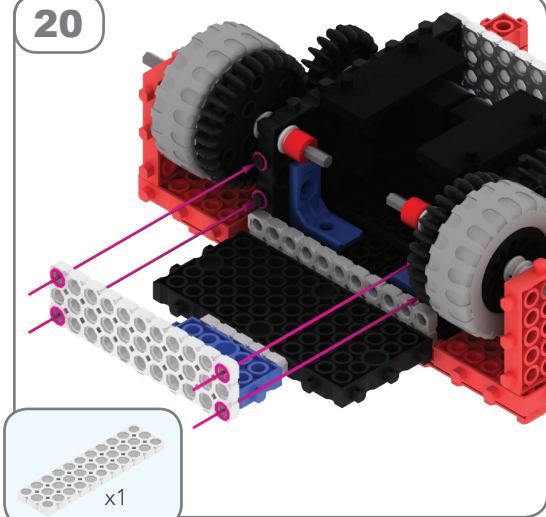

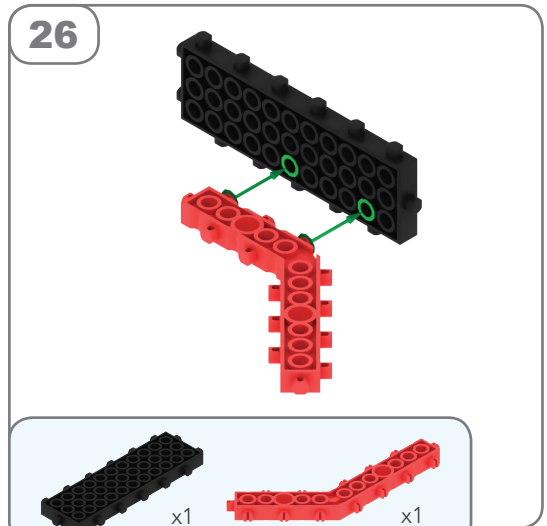
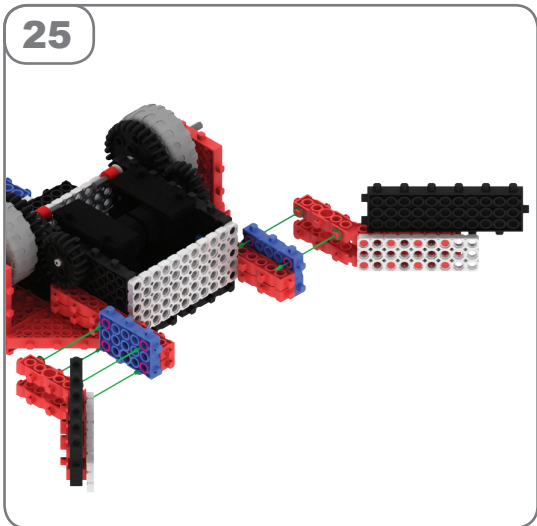
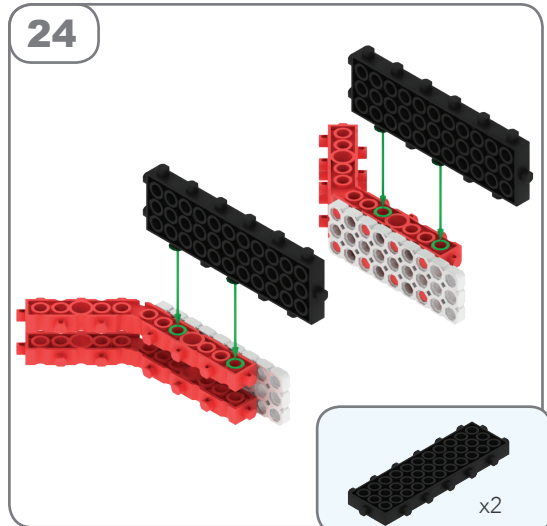
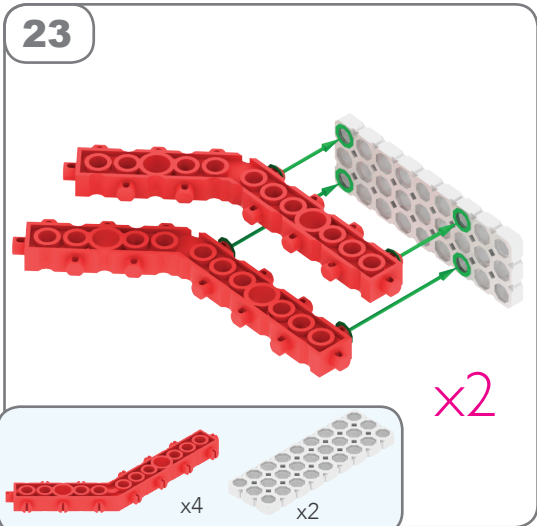
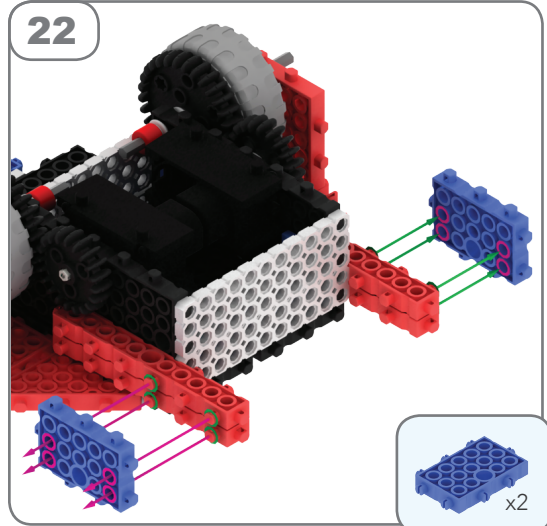
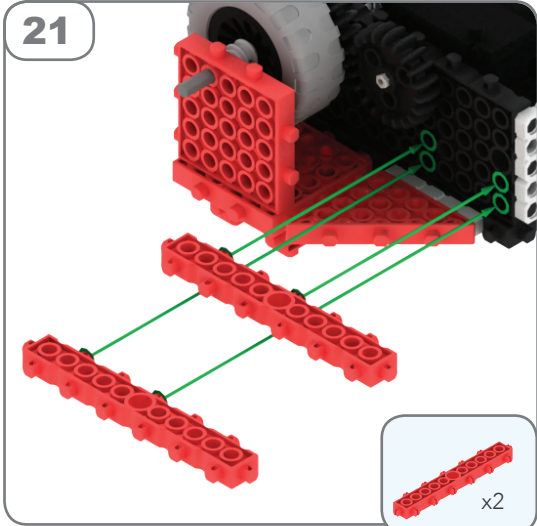

27

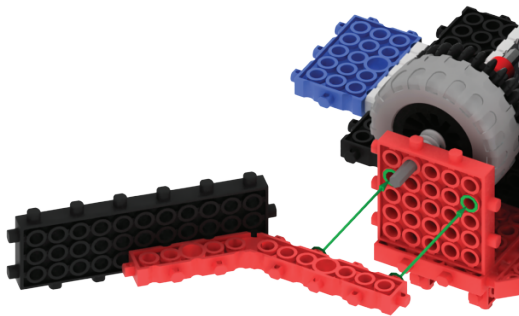

28

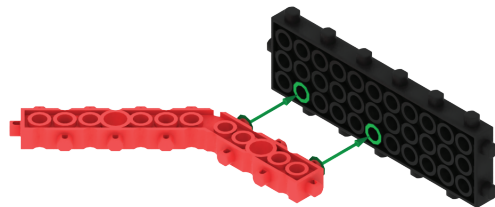

29

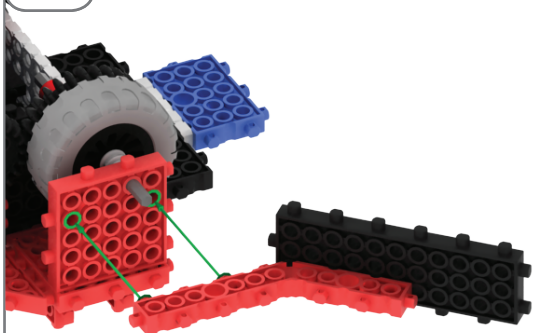

30

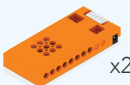
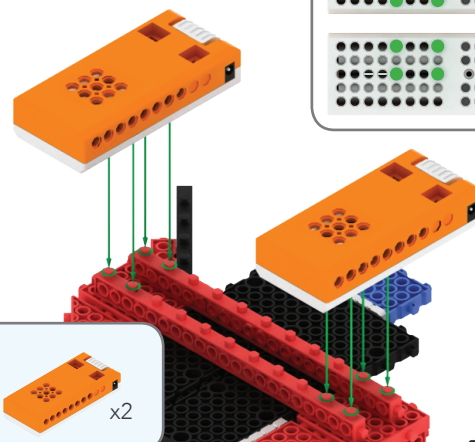

31

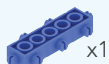
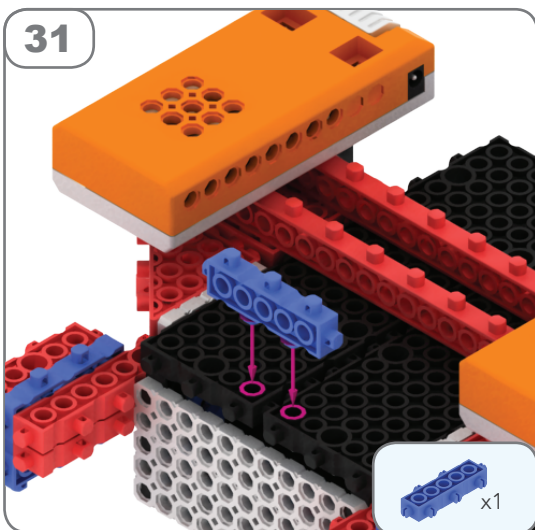

32

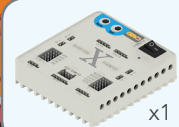
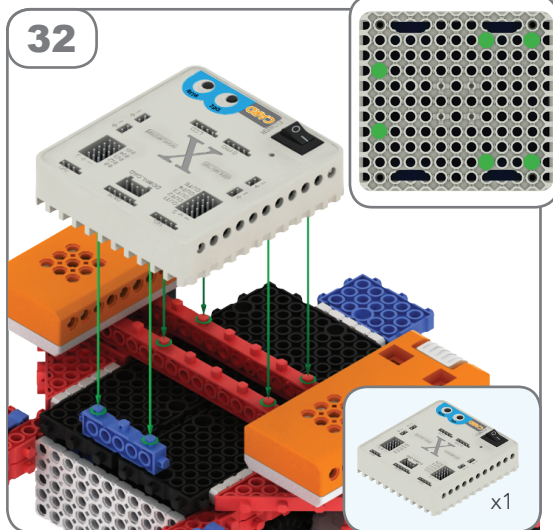

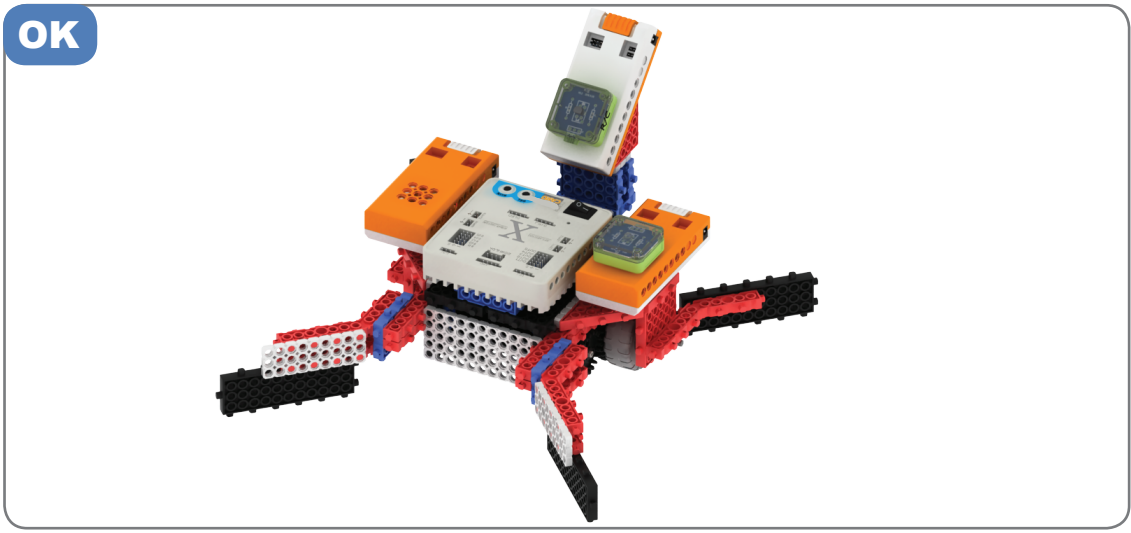
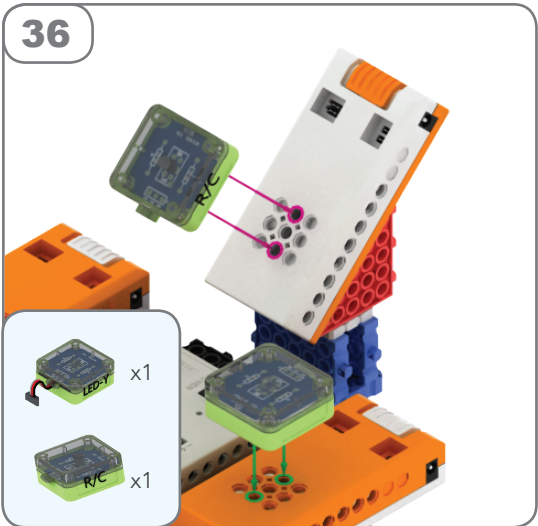
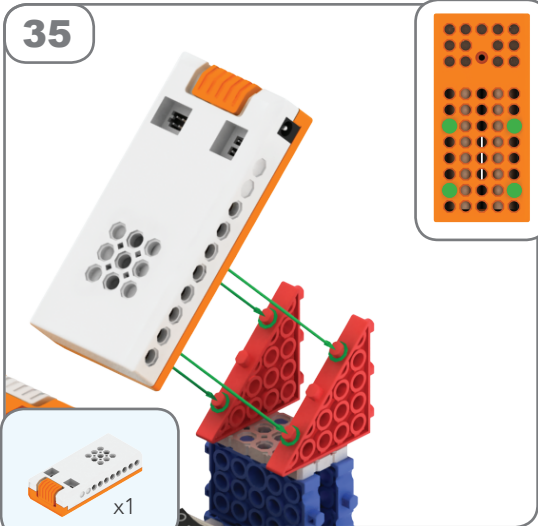
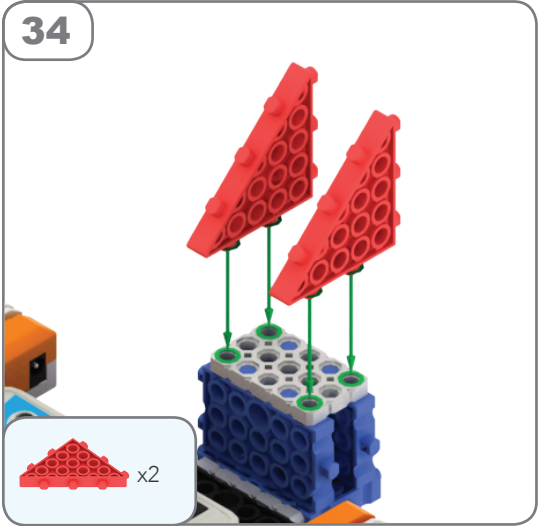
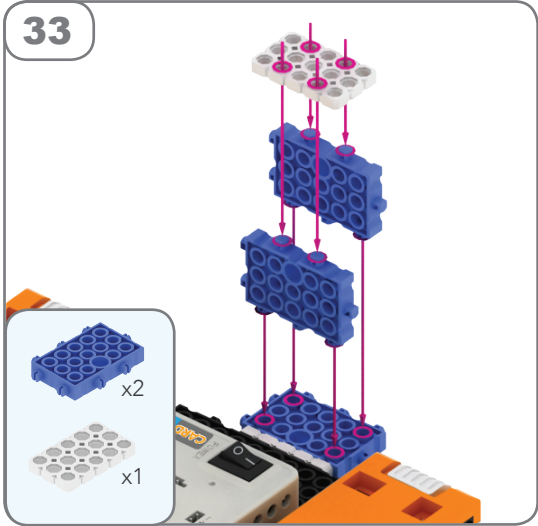

¿Cómo hacer la conexión?

- 1 Conecta el sensor R/C con la placa base como se indica.
- 2 Conecta los dos motores con la placa base. Fíjate en que el cable negro va en el +.
- 3 Conecta el LED Y con el puerto OUT2.
- 4 Conecta los portapilas a la placa base.

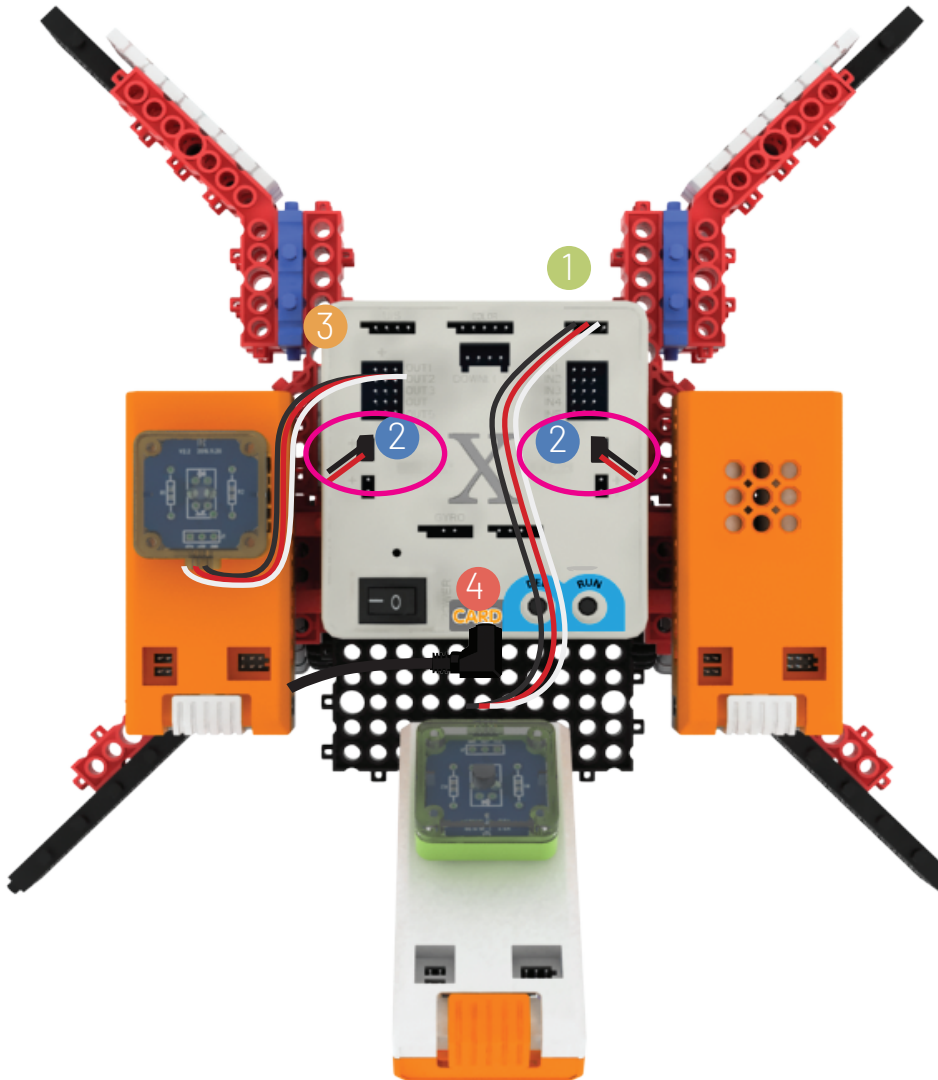

Practica

Enciende la placa pulsando POWER, luego pulsa RUN y, después, DEL cinco veces. La X parpadeará en color azul, entonces pulsa RUN para activar el modo 6.

Usa el mando a distancia para controlar a tu robot futbolista.

Construye una portería, juega con tu robot y ¡marca un gol!

