

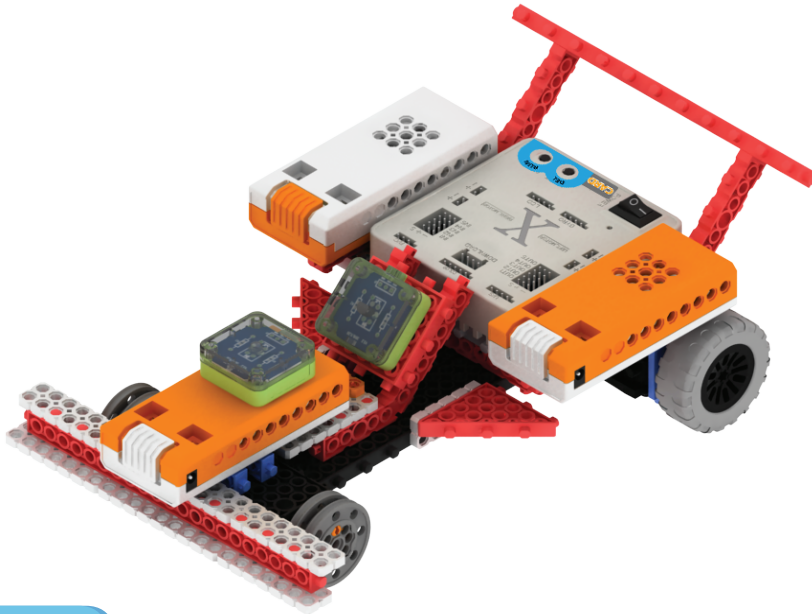

19 Coche de carreras

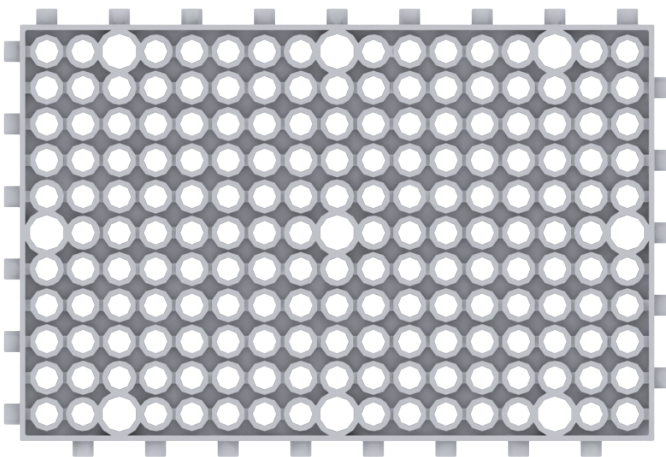

Piezas



Bloque 11x17 (1)



Bloque N 2x5 (2)



Bloque N 2x7 (5)



Bloque N 3x7 (1)



Bloque N 2x9 (2)



Remache
básico (8)



Remache doble
tipo 1 (2)



Arandela (4)

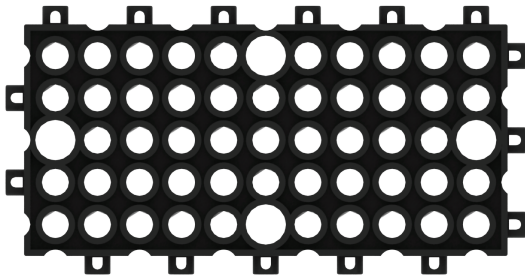

Bloque 5x11 (1)

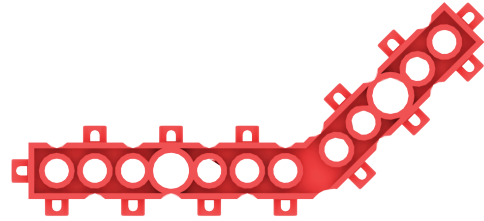

Bloque 135° (4)

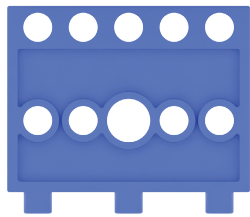

Soporte de motor (2)

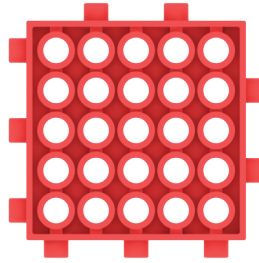

Bloque 5x5 (1)

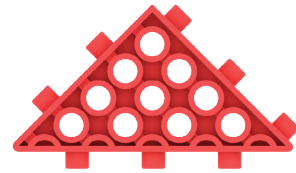

Bloque triangular (2)

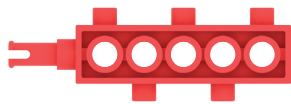

Bloque con eje (4)

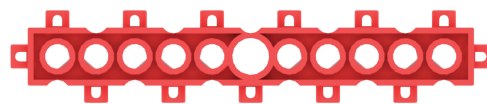

Bloque 1x11 (4)

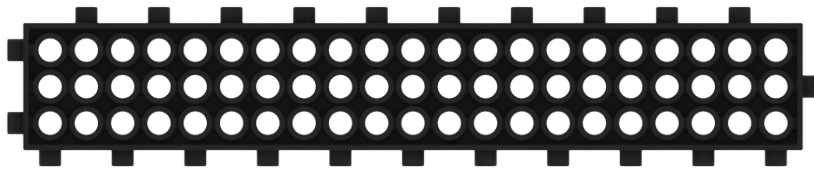

Bloque 3x21 (2)

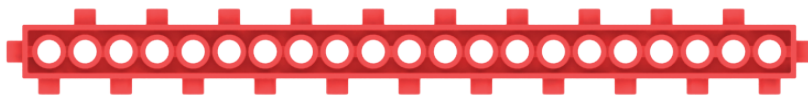

Bloque 1x21 (2)

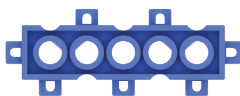

Bloque 1x5 (2)

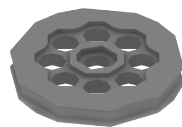

Llanta/Hub 1 (2)

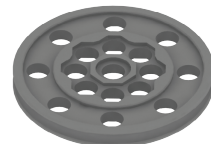

Llanta/Hub 2 (4)



Motor 2 (2)

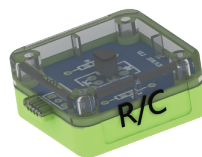

R/C sensor (1)

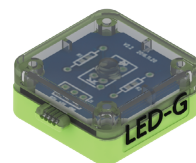

LED G (1)

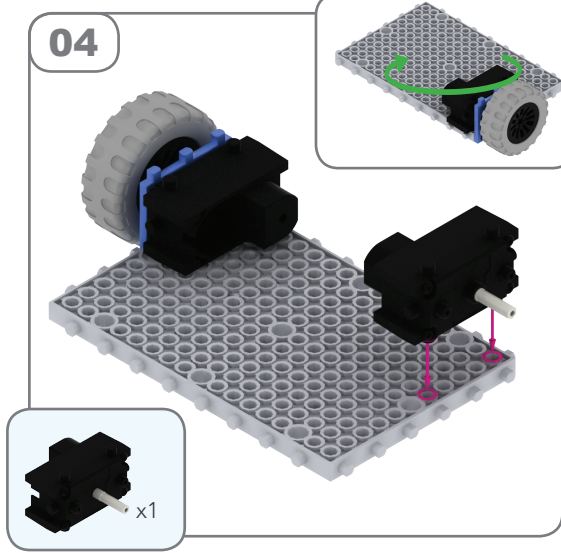
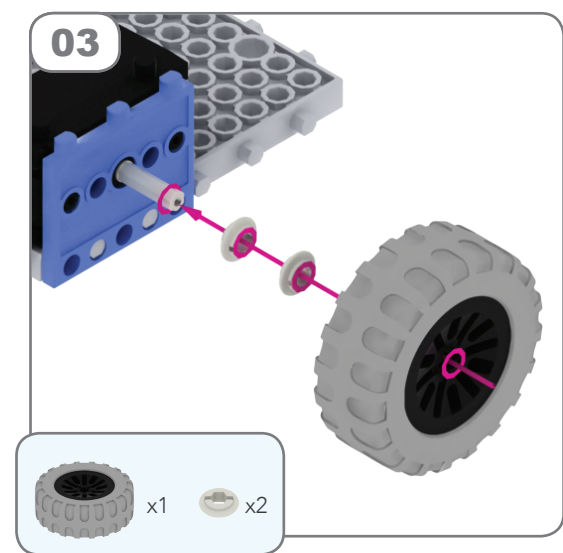
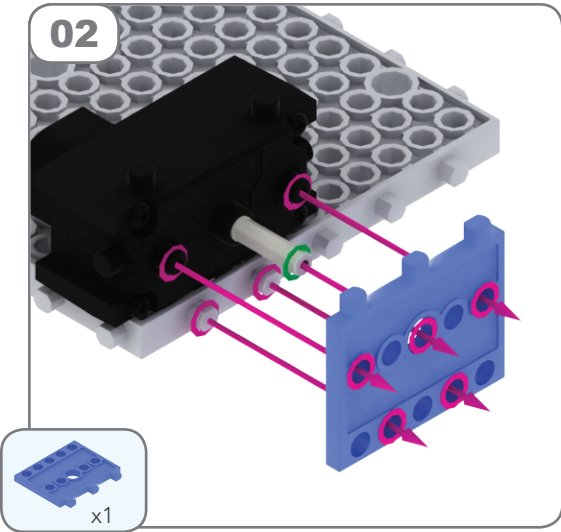
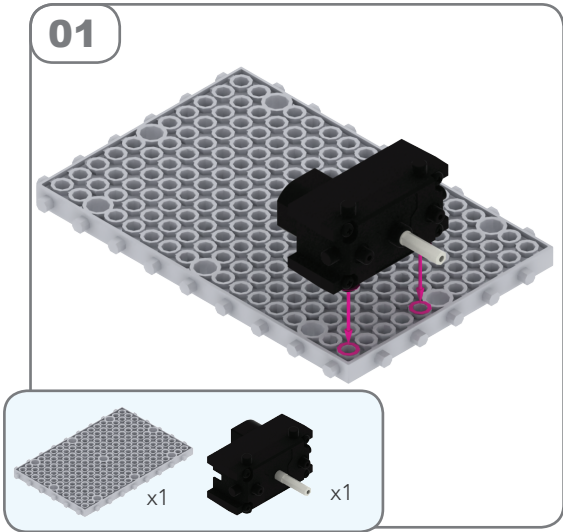
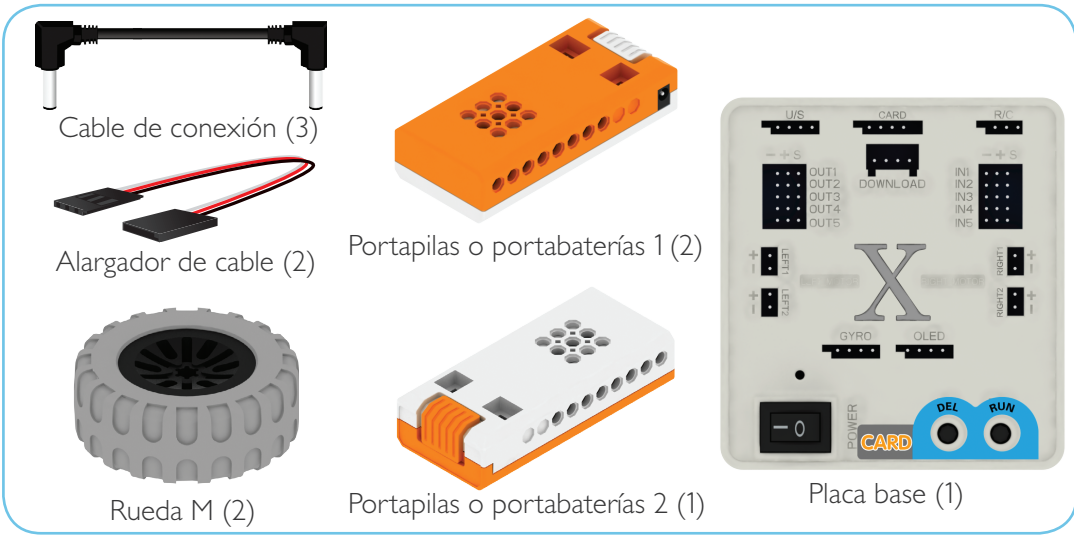

05

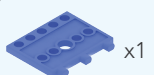
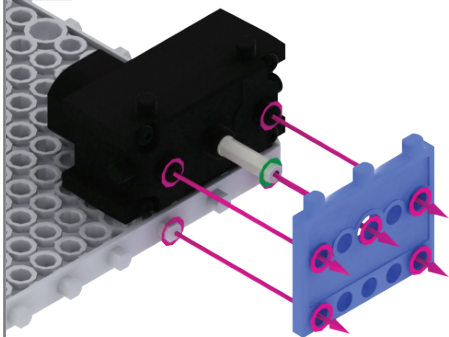

06

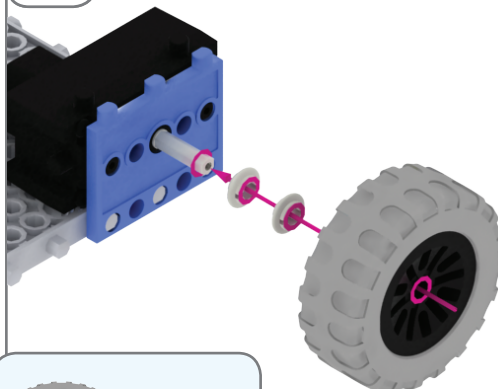

07

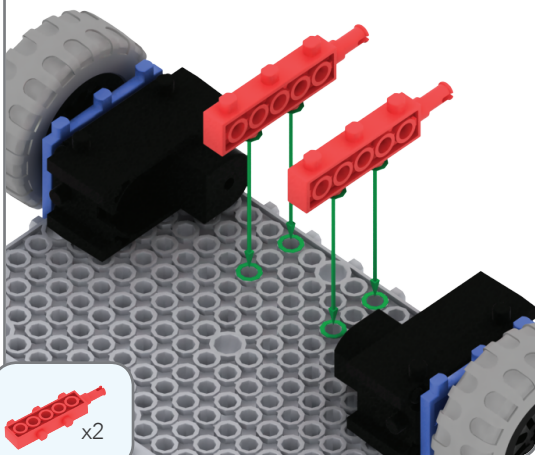

08

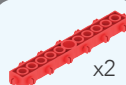
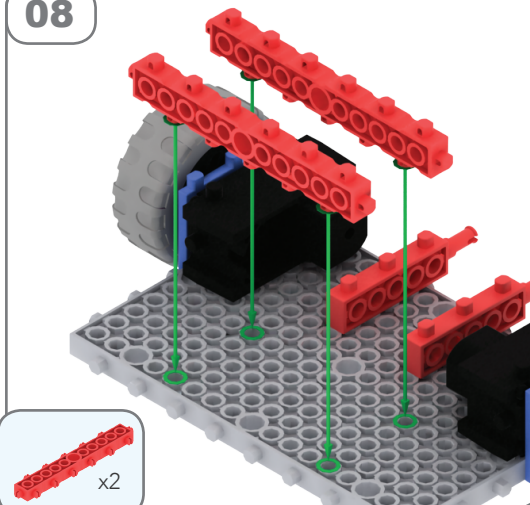

09

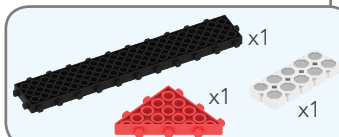
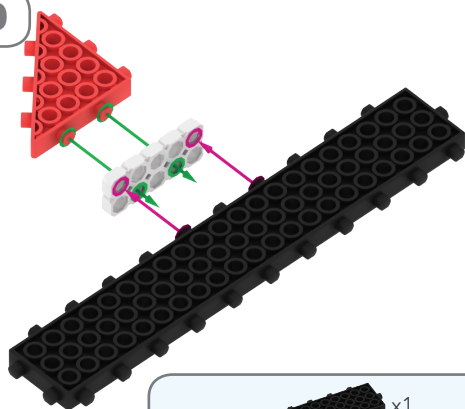

10

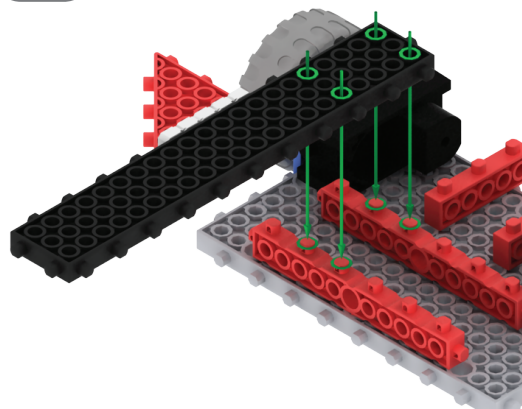

11

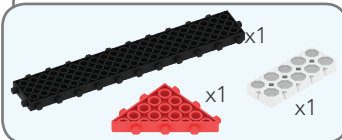
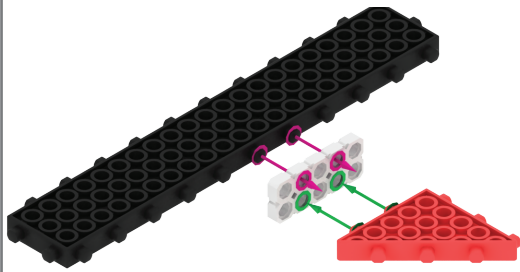

12

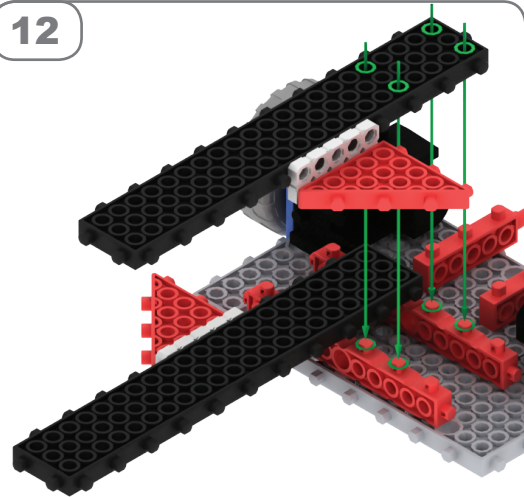

13

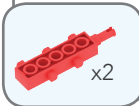
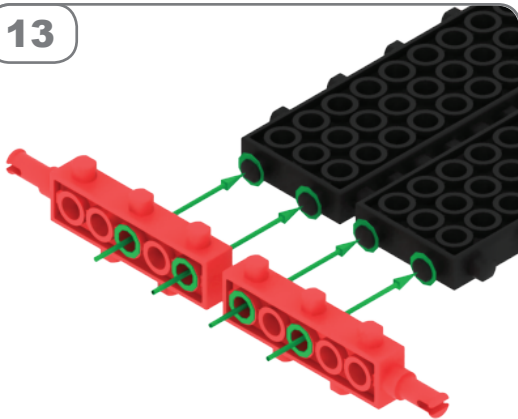

14

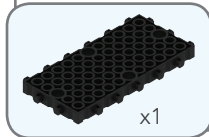
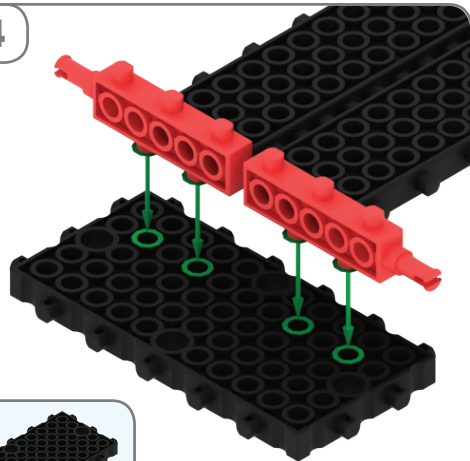

15

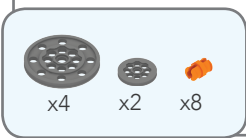
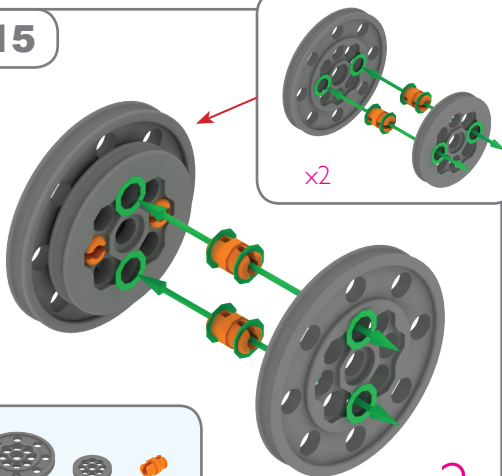

x2

16

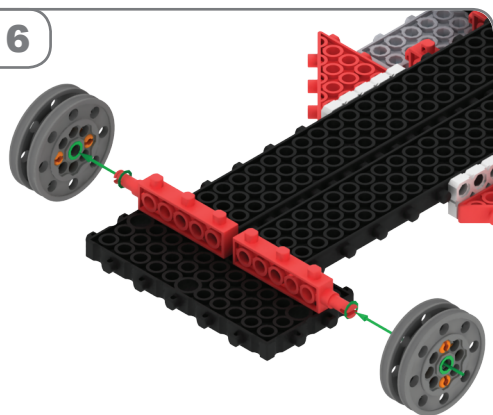

17

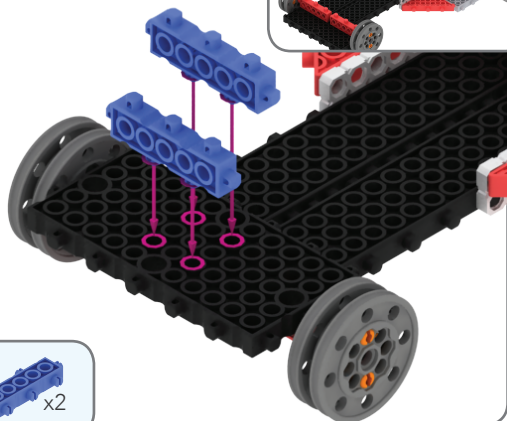

18

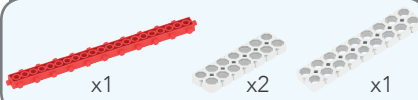
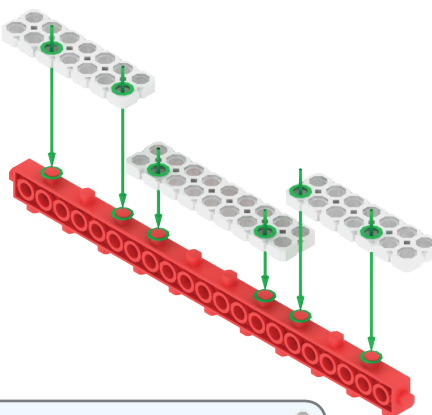

19

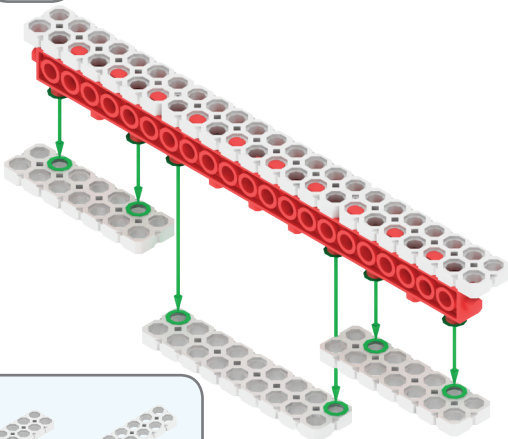

20

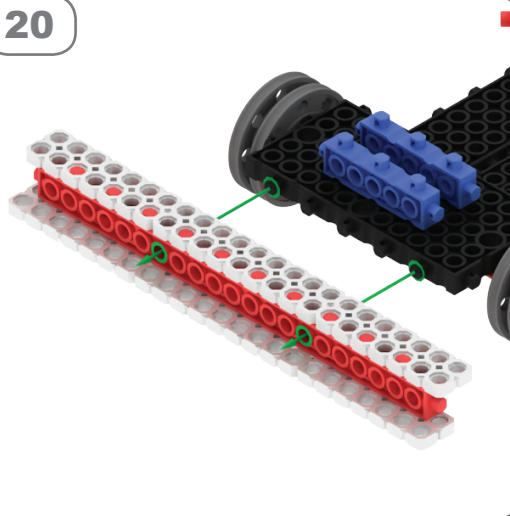

21

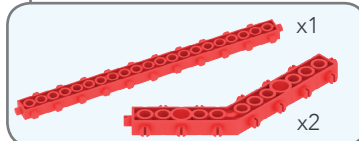
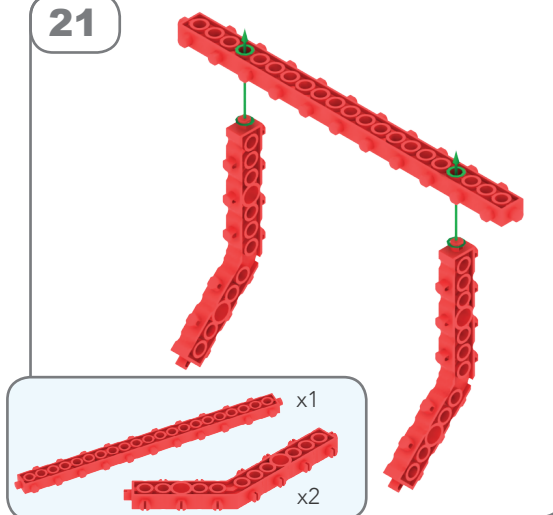

22

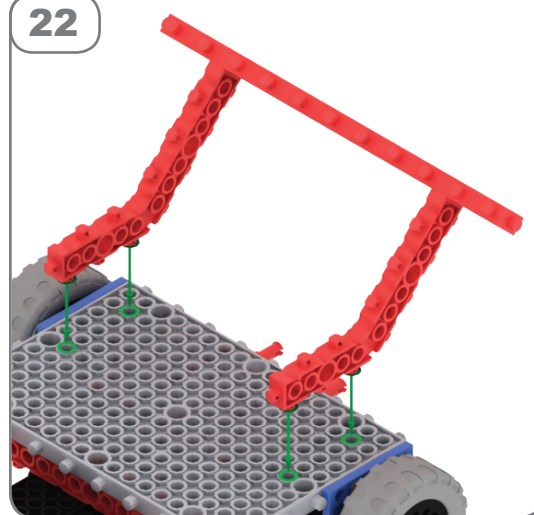

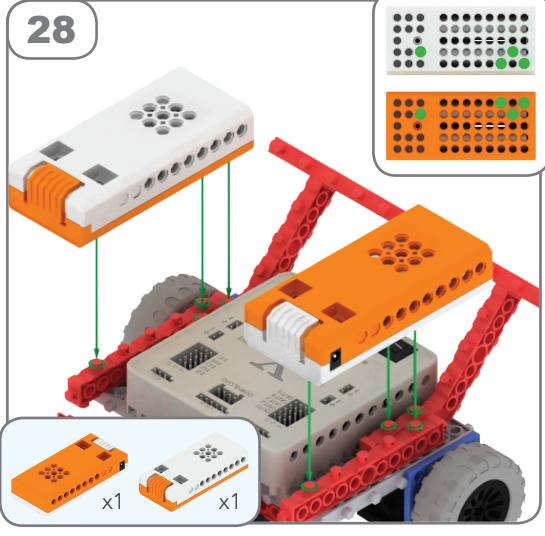
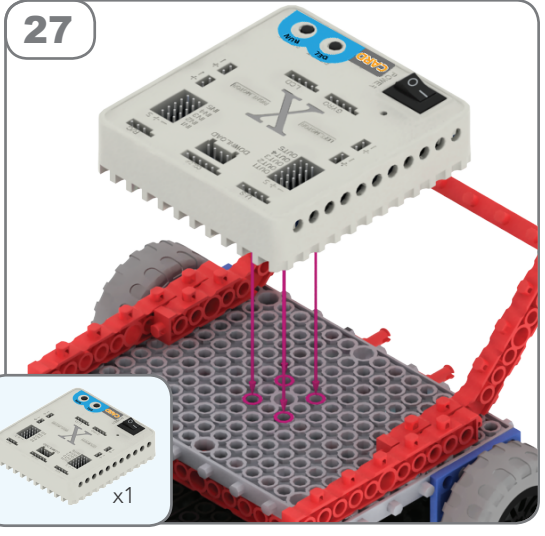
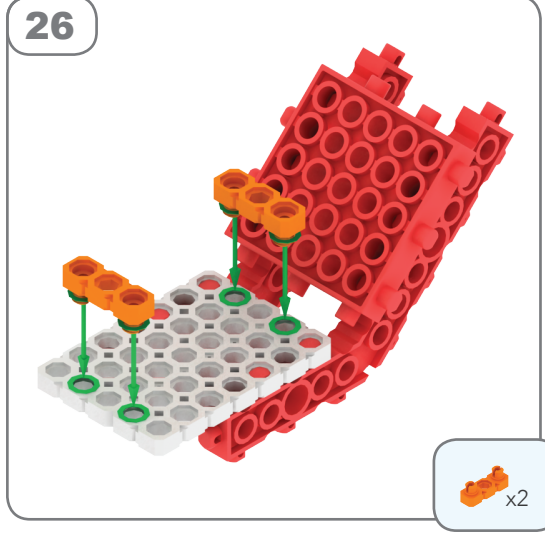
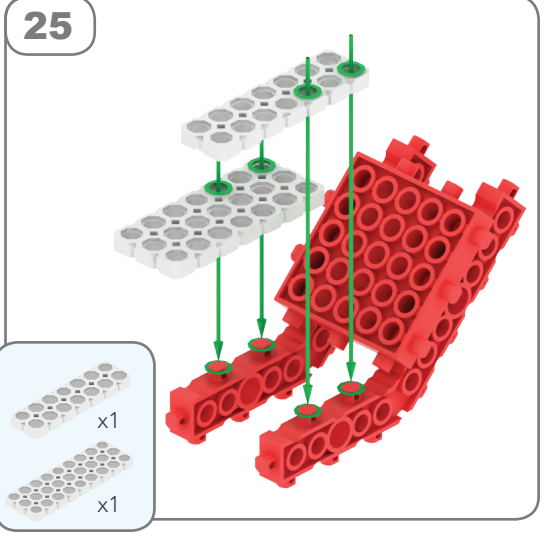
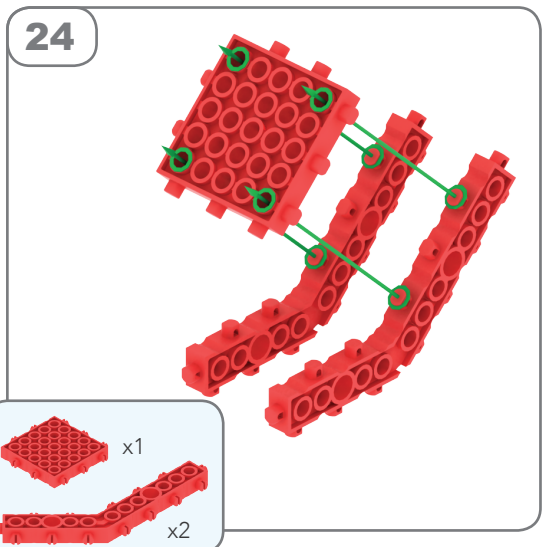
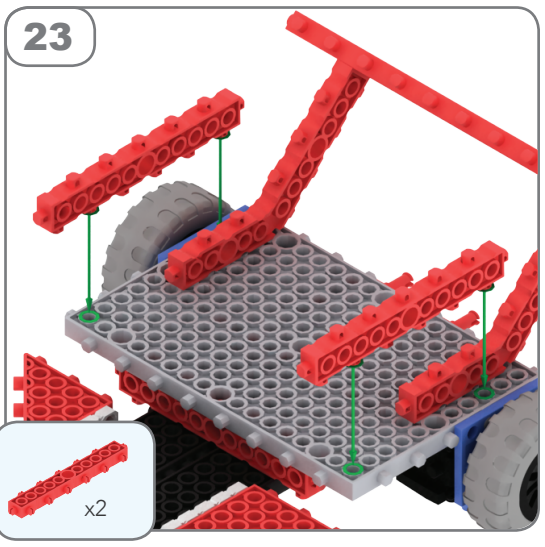

29

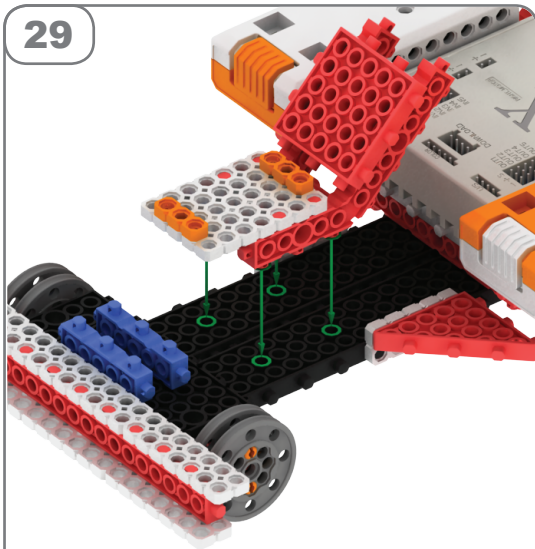

30

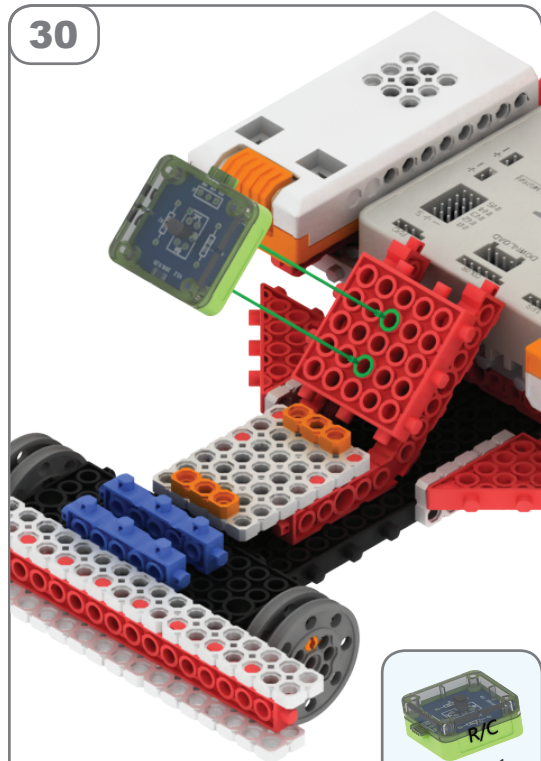

31

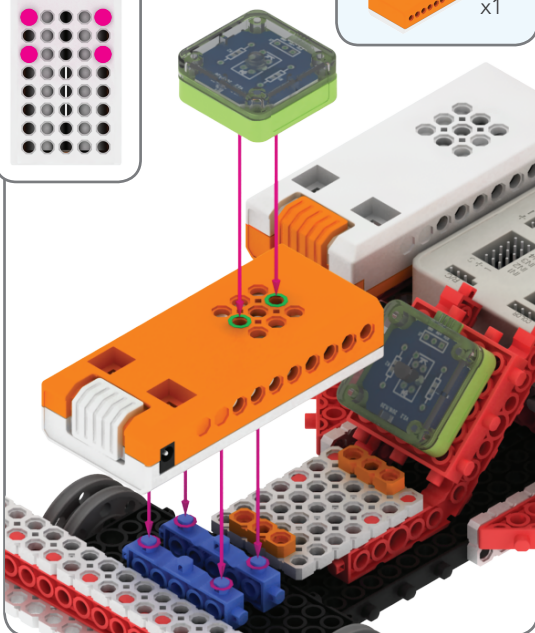
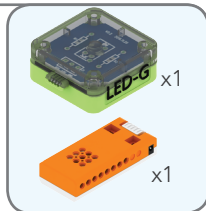

OK

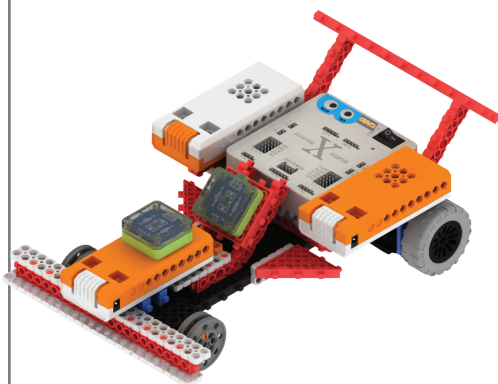

¿Cómo hacer la conexión?



- 1 Conecta el sensor R/C con la placa base tal y como se muestra arriba.
- 2 Conecta el LED G en el puerto OUT2.
- 3 Conecta los dos motores con la placa base.
- 4 Conecta el portapilas con la placa.

Los portapilas suministrarán energía cuando se conecten a la placa con el cable de conexión negro, independientemente de la posición de sus interruptores.

Practica

Enciende la placa pulsando POWER, luego pulsa RUN y, después, DEL cinco veces. La X parpadeará en color azul, entonces pulsa RUN para activar el modo 6.

Usa el mando a distancia para controlar el coche.

