

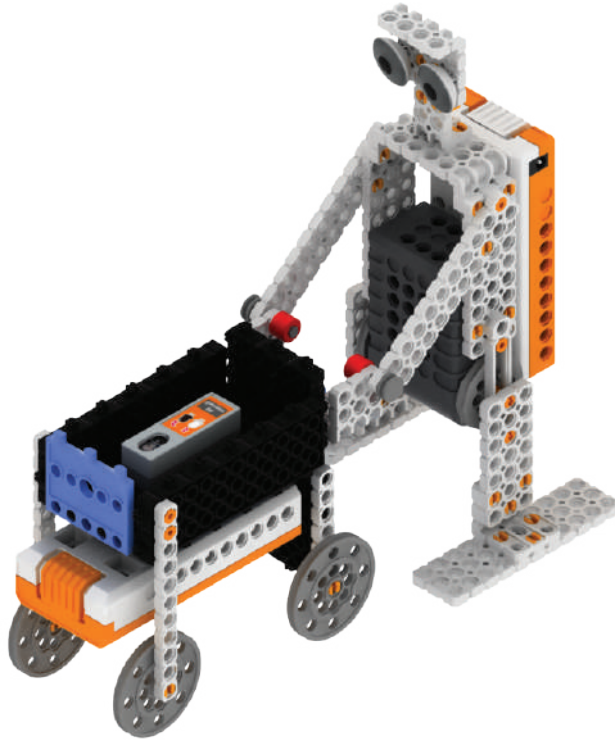

9 Carrito de la compra



Piezas



Bloque N 3×11 (2)



Bloque N 2×11 (2)



Bloque N 3×7 (2)



Bloque N 3×9 (2)

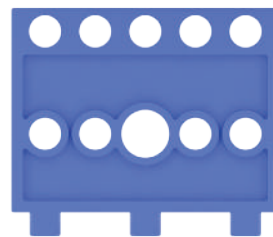

Soporte de motor (1)



Bloque N 1x7 (2)



Bloque N 1x11 (2)



Adaptador L 2x3 (1)



Adaptador L 2x4 (2)



Adaptador L 3x4 (4)



Adaptador L 3x3 (2)

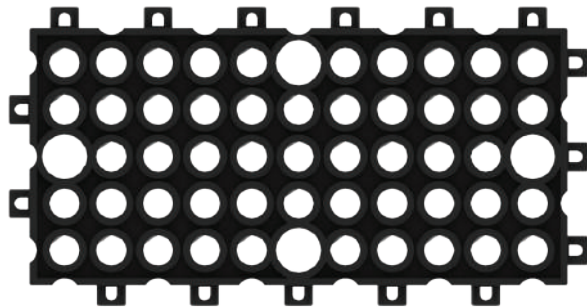

Bloque 5x11 (2)



Bloque de unión B1 (2)



Adaptador L (2)

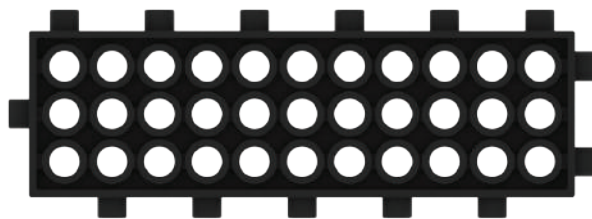

Bloque 3x11 (2)

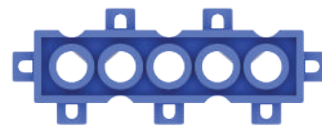

Bloque 1x5 (3)



Remache S (8)



Remache básico (34)



Remache L (4)



Llanta/Hub 1 (4)



Remache doble tipo 1 (2)



Conector de eje (2)



Bloque ojo (2)



Goma de eje roja/
Red bush (2)



Sensor de infrarrojos (1)



Motor 1 (1)



Portapilas o portabaterías 1 (1)



Cable de conexión (1)

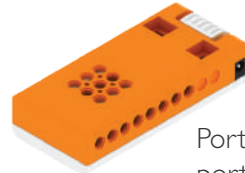

Portapilas o portabaterías 2 (1)

01

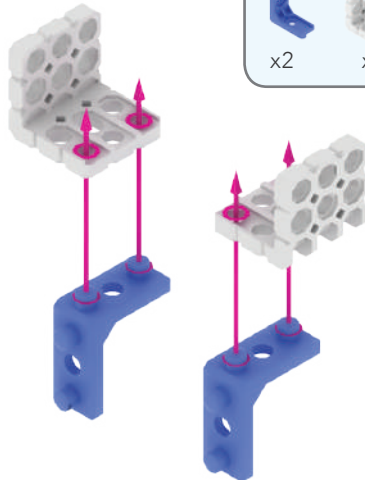

x2

x2

02

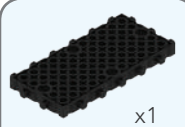
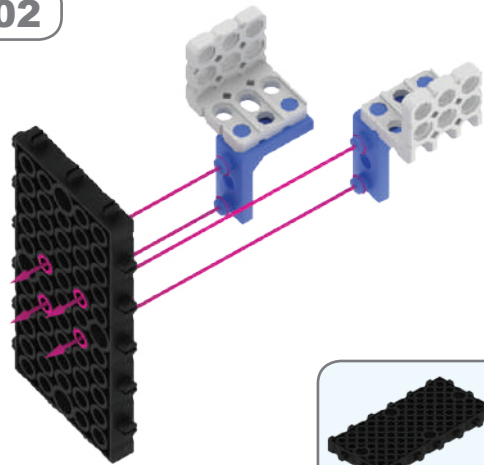

x1

03

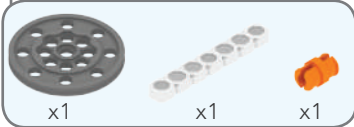
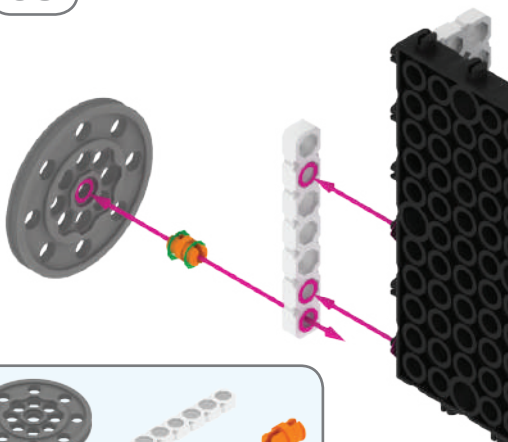

x1

x1

x1

04

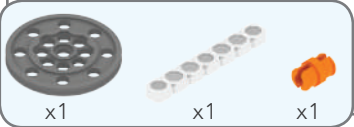
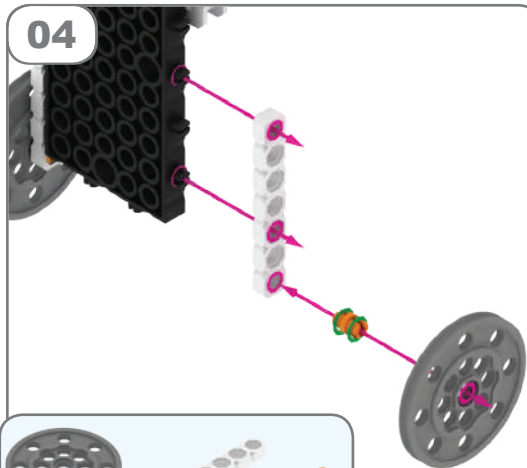

x1

x1

x1

05

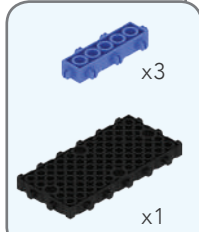
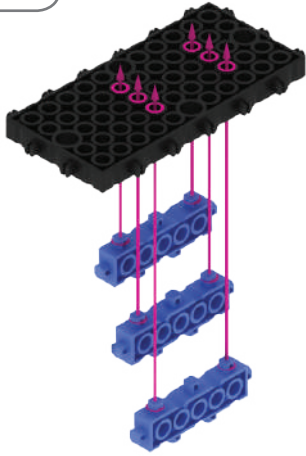

06

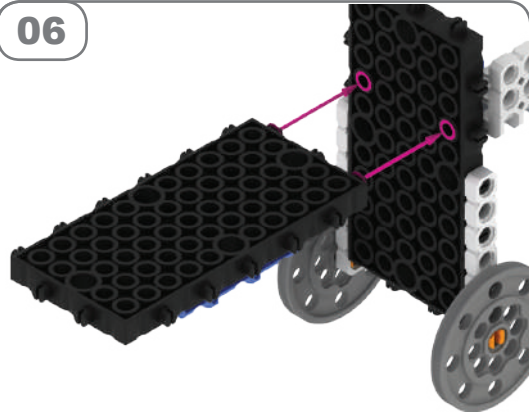

07

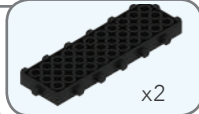
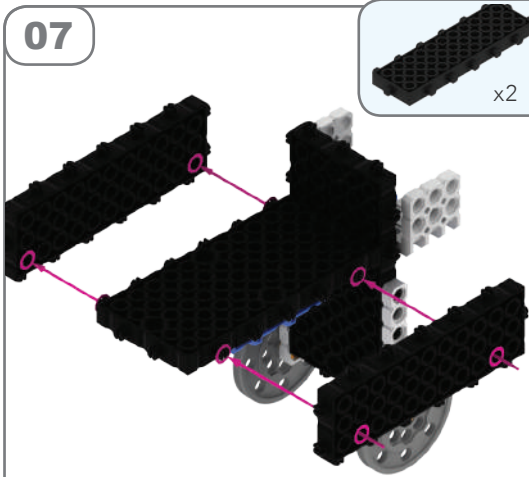

08

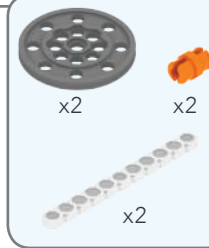
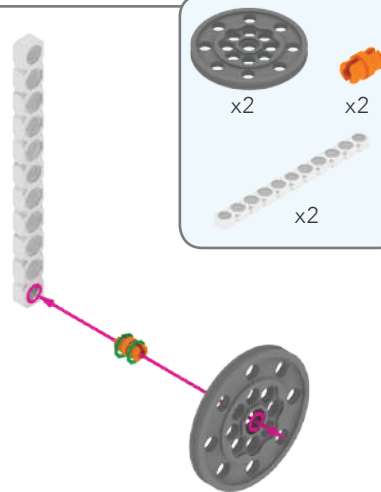

09

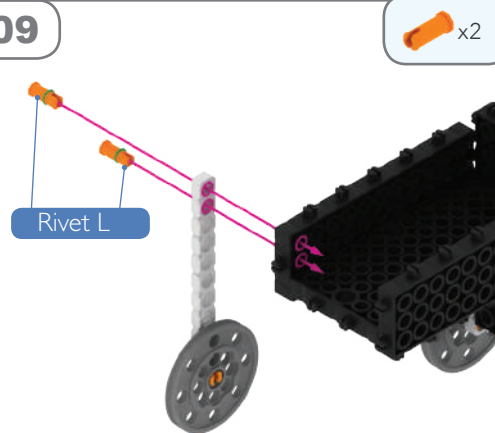

10

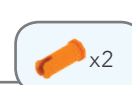
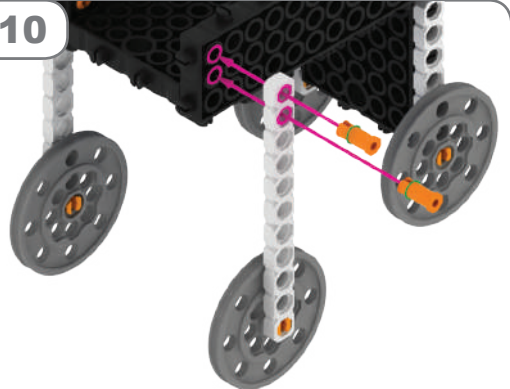

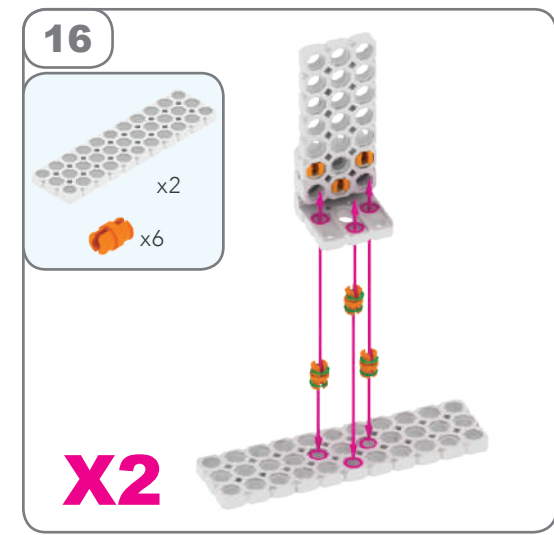
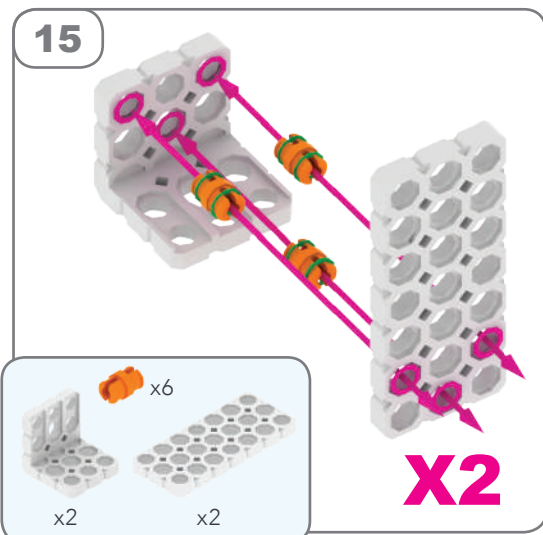
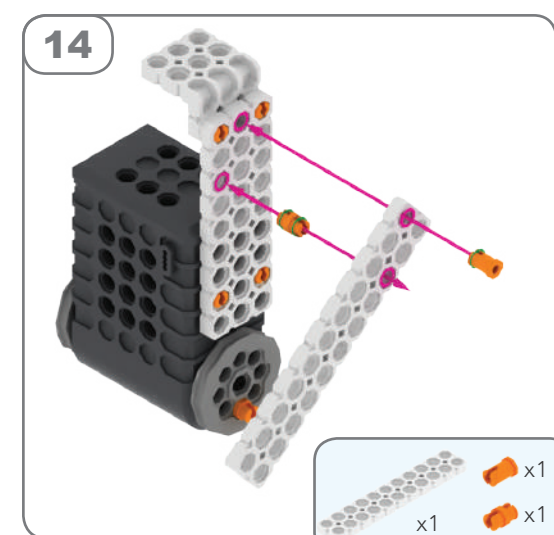
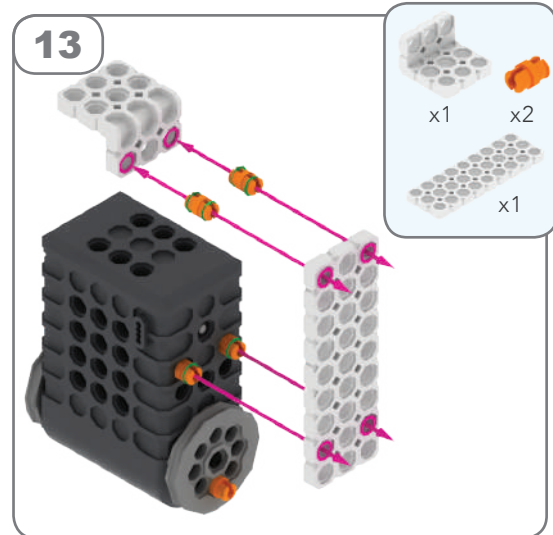
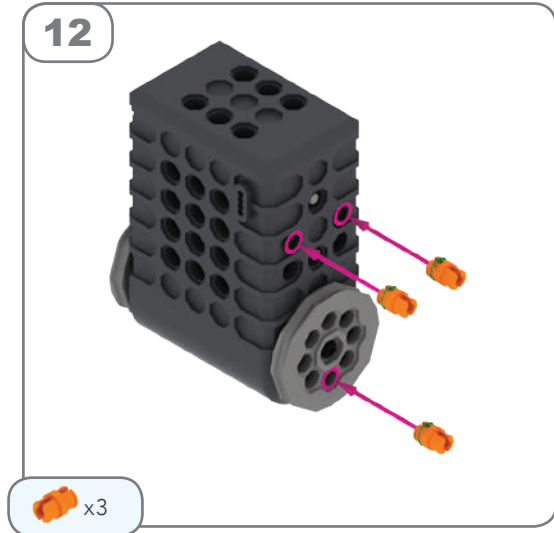
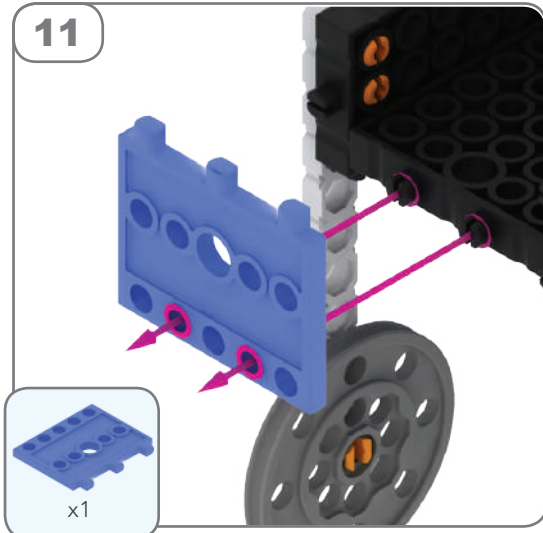

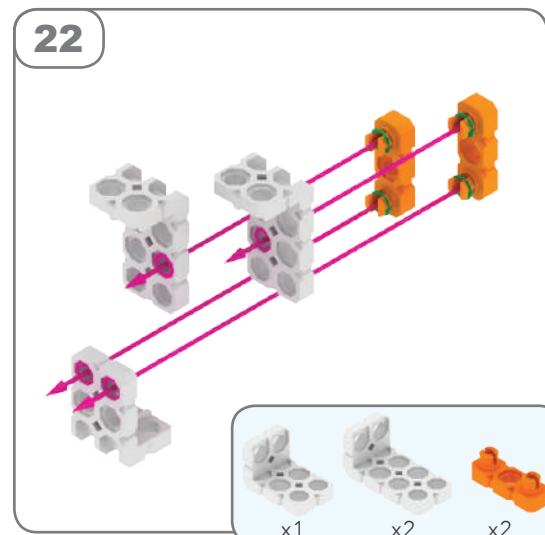
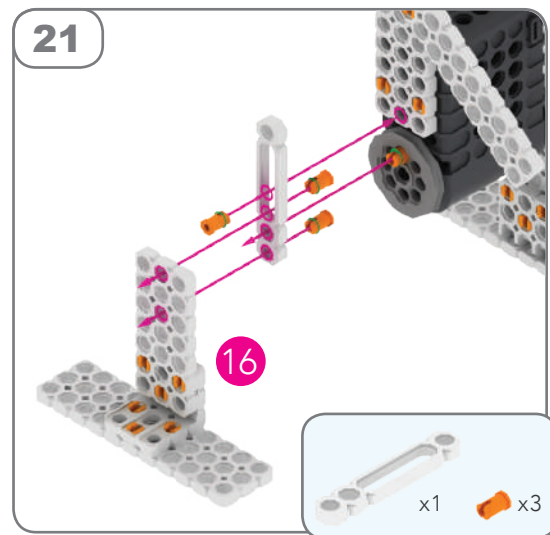
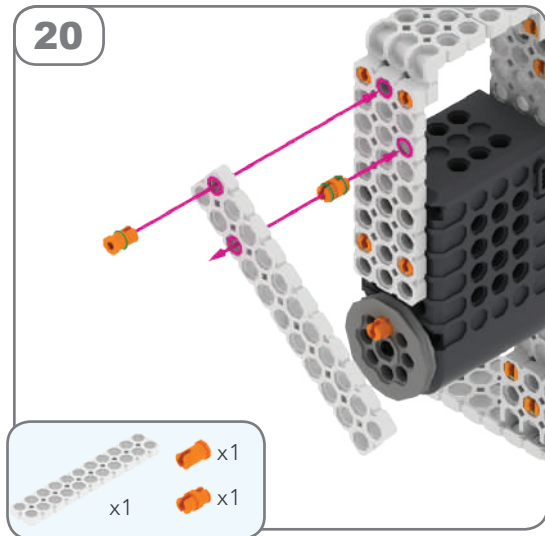
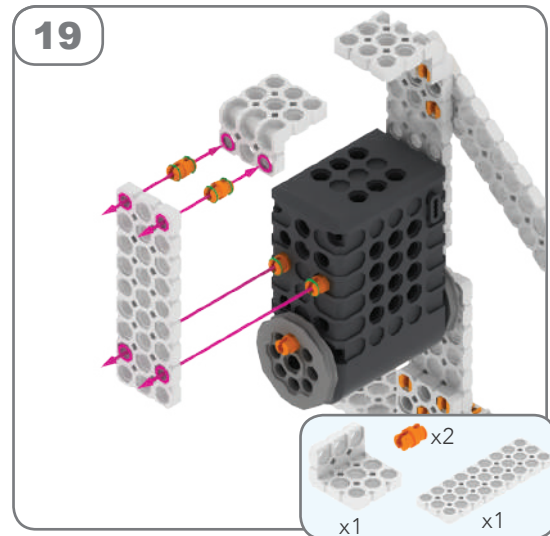
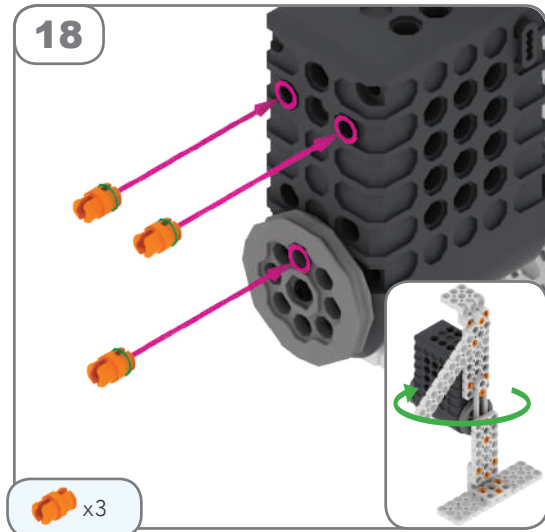
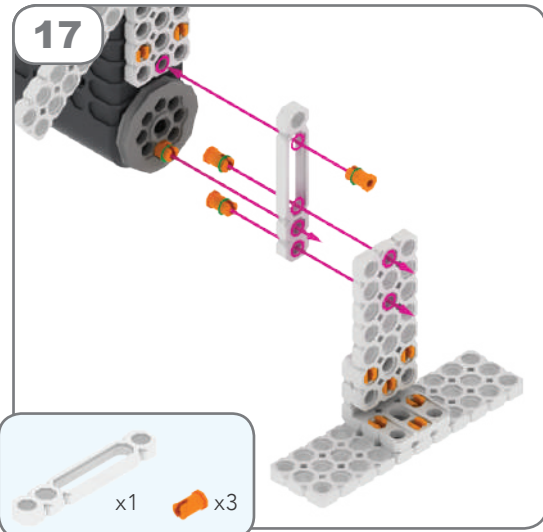

23

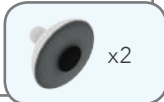
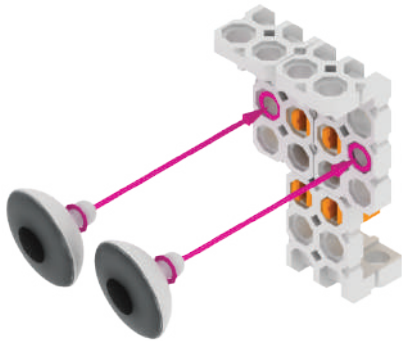

24

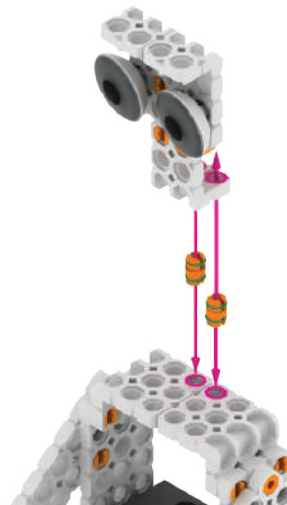

25

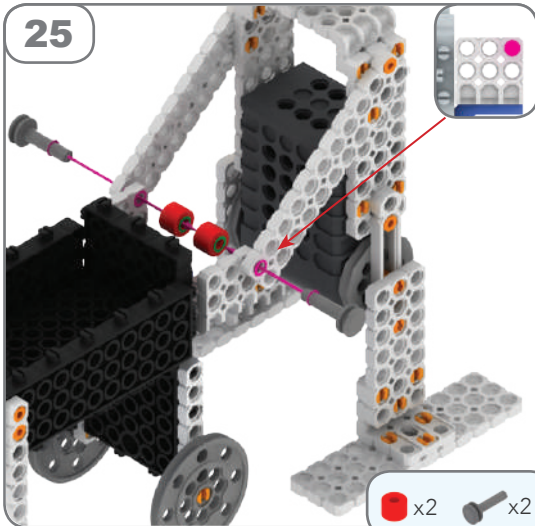

26

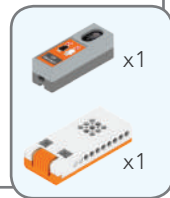
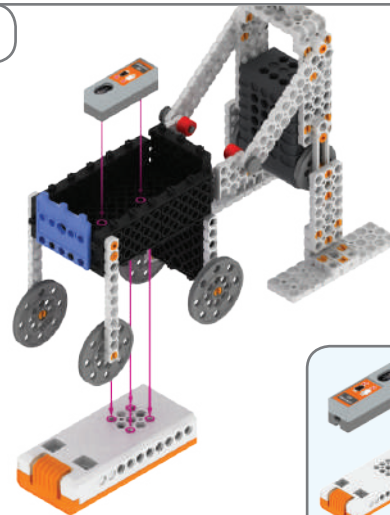

27

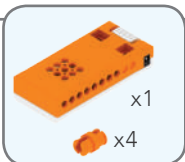
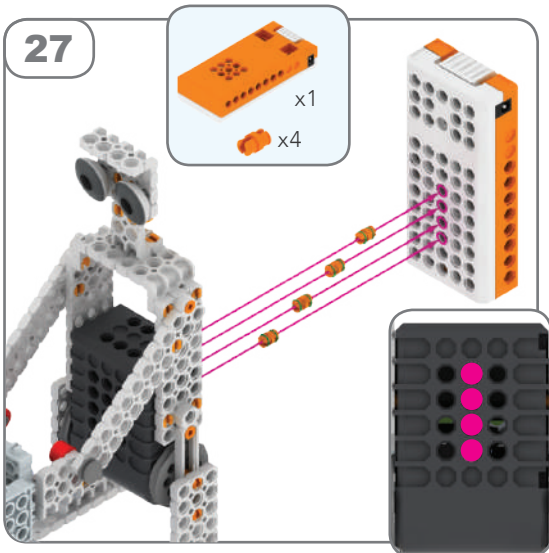

OK



¿Cómo hacer la conexión?

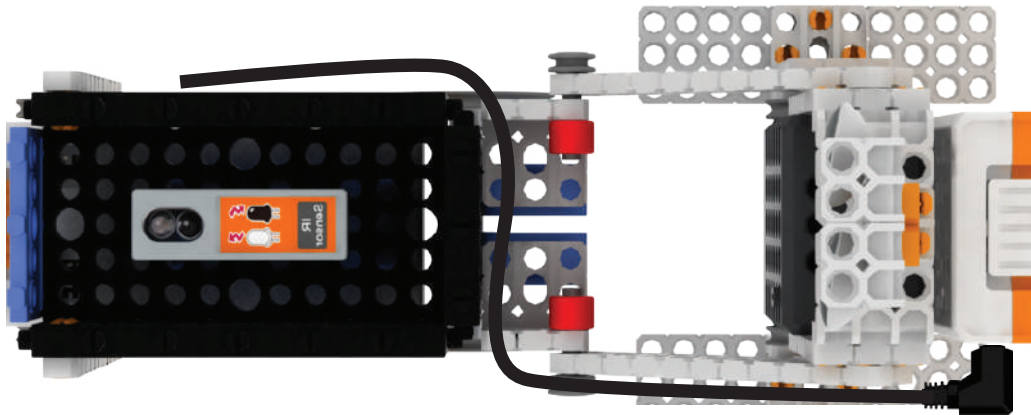

La conexión del sensor de infrarrojos al portabaterías es: el cable negro al "-", el cable rojo al "+" y el blanco a "S".

El rojo del cable del motor se conecta con el + y el negro con el -, lo que hará que nuestro robot avance hacia delante.

IMPORTANTE: Cuando no uses el robot, desconecta el sensor infrarrojo para evitar que las pilas se agoten.