

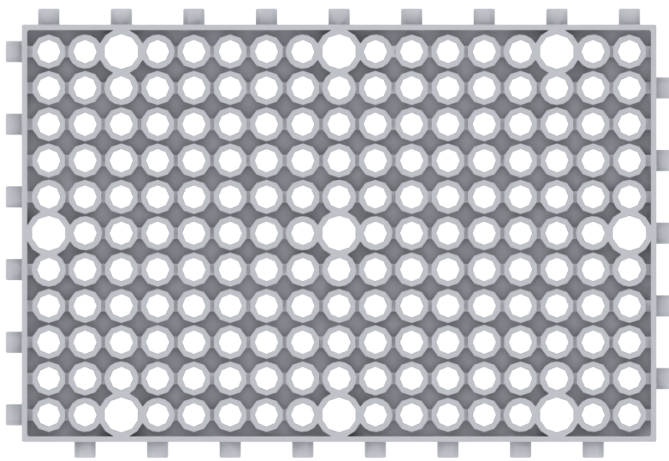

16 Luchador de sumo



Piezas



Bloque 11x17 (1)

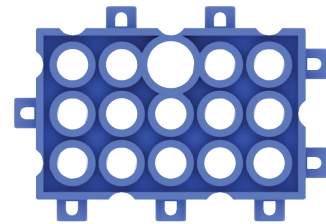

Bloque 3x5 (3)

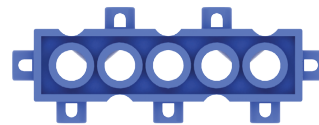

Bloque 1x5 (2)

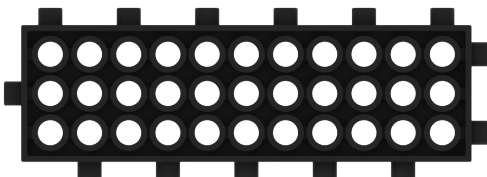

Bloque 3x11 (2)



Bloque N 3x11 (1)

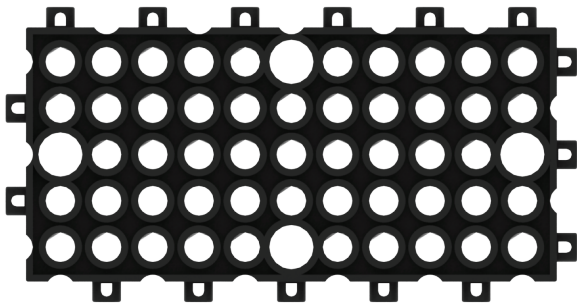

Bloque 5x11 (2)



Bloque ojo (2)



Adaptador L (6)

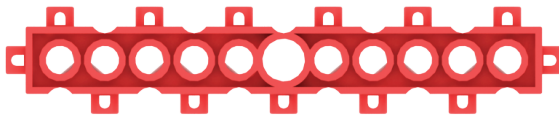

Bloque 1x11 (2)

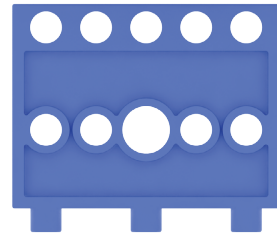

Soporte de motor (2)

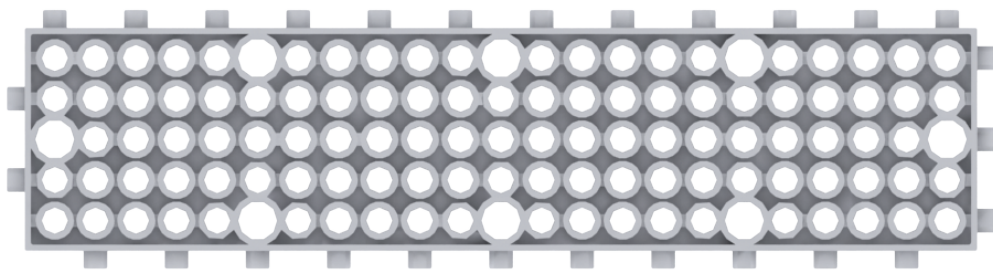

Bloque 5x23 (2)



Bloque de unión 1 (1)



Bloque de unión 2 (1)

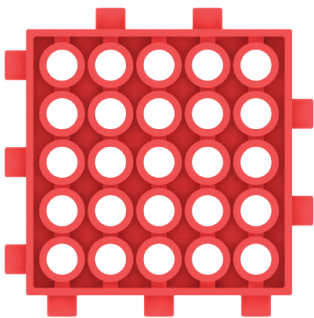

Bloque 5x5 (3)

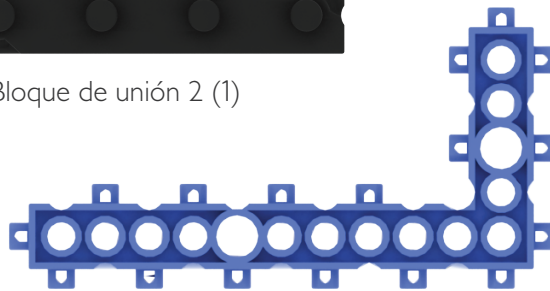

Bloque 90° (4)

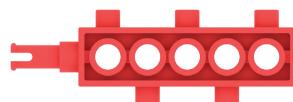

Bloque con eje (4)



Bloque N 1x5 (1)



Sensor de infrarrojos (2)

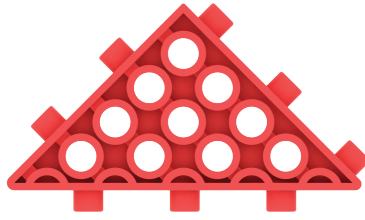

Bloque triangular (2)



Conector de eje (2)



Goma de eje roja/
Red bush (2)

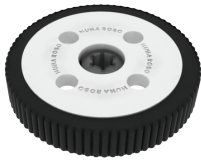

Rueda M (2)



Motor 2 (2)



Cable de conexión(3)

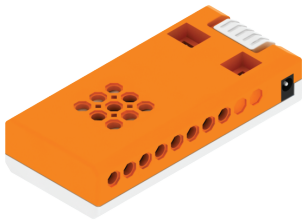

Portapilas o
portabaterías 1 (2)

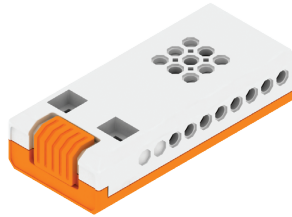

Portapilas o
portabaterías 2 (1)



Placa base (1)

01

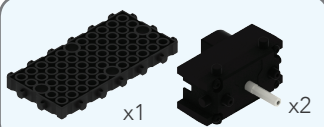
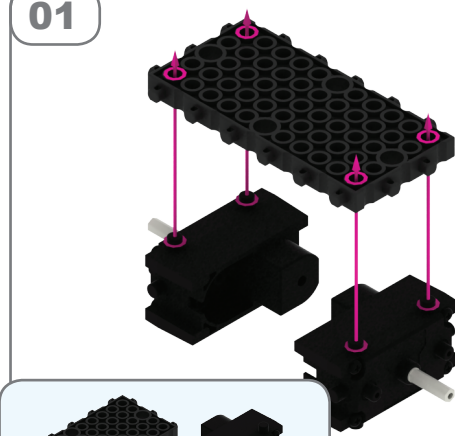

02

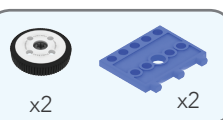
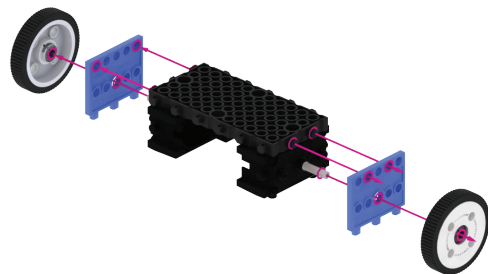

Nota: el triángulo rojo ▲ señala la posición.

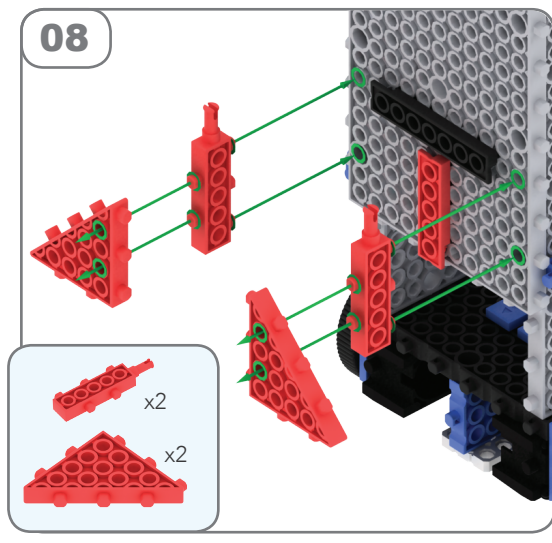
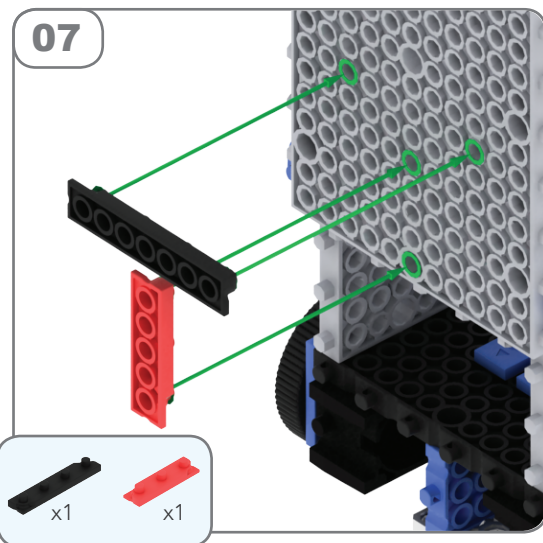
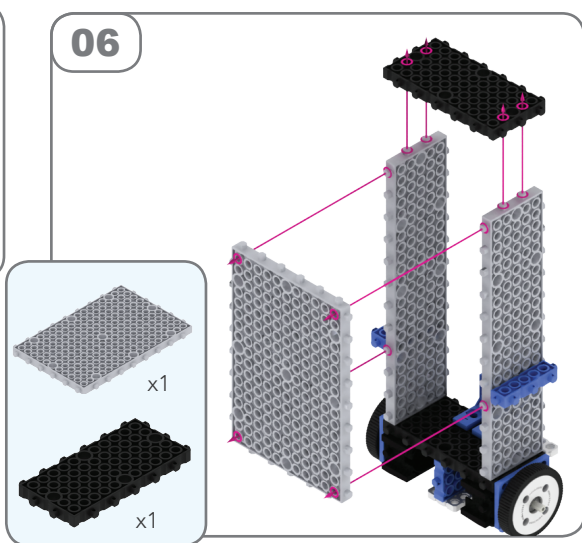
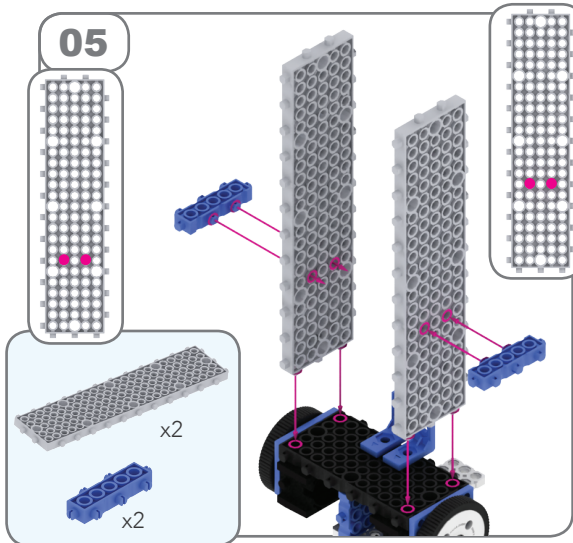
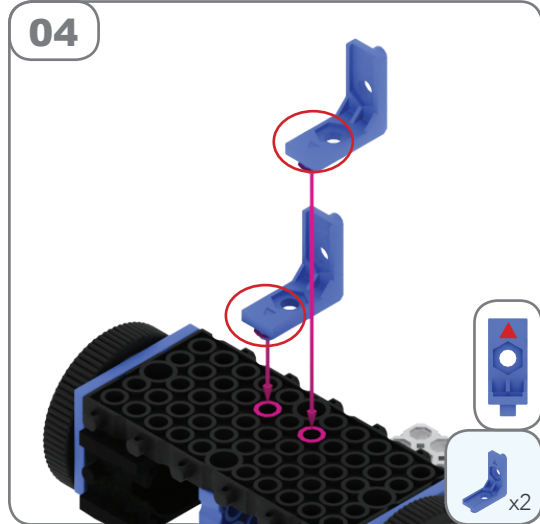
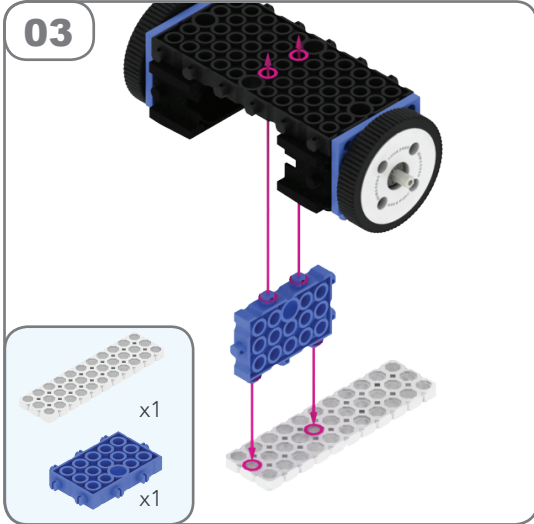

Nota: el triángulo rojo ▲ señala la posición.

09

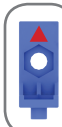
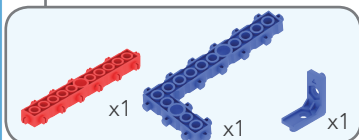
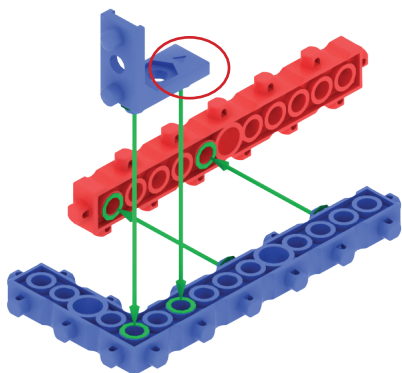

10

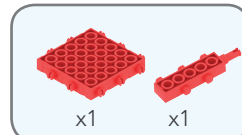
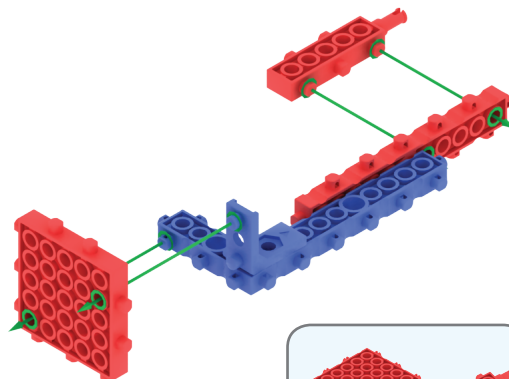

Nota: el triángulo rojo ▲ señala la posición.

11

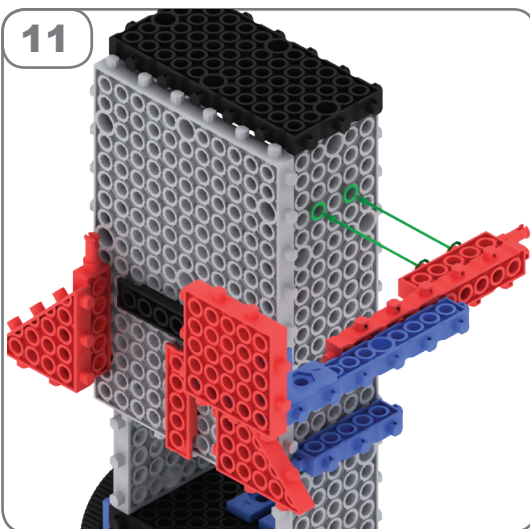

12

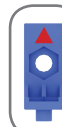
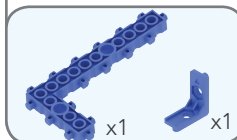
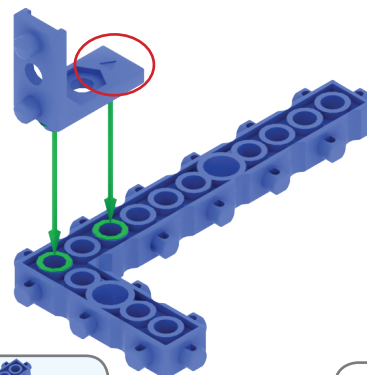

13

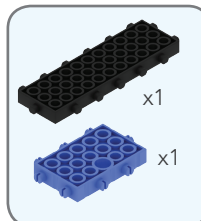
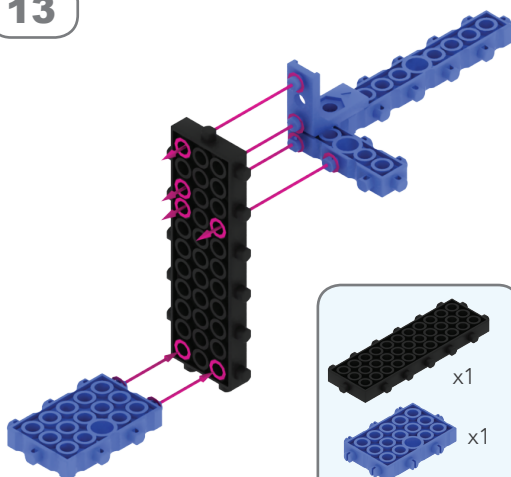

14

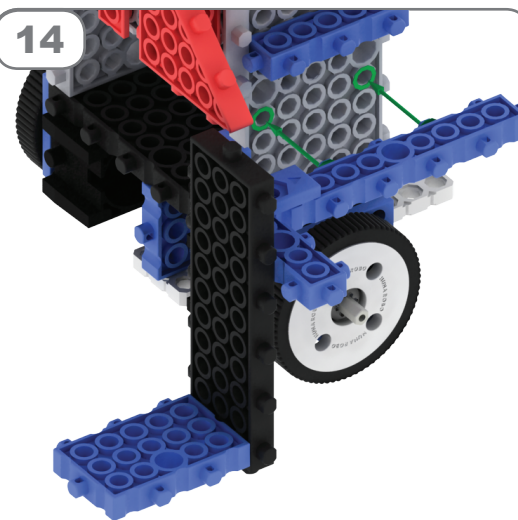

15

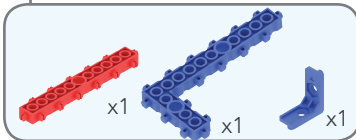
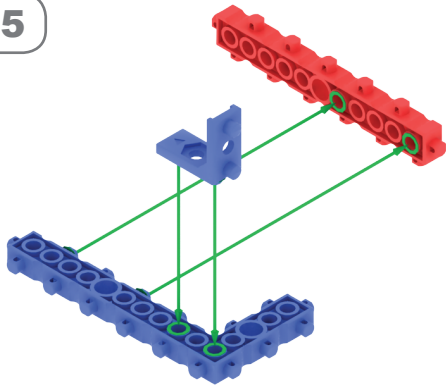

16

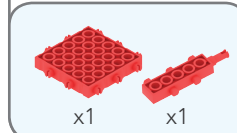
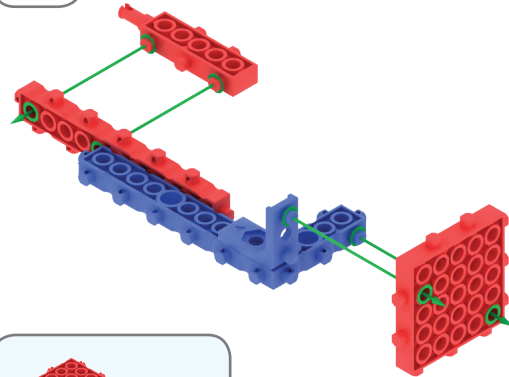

Nota: el triángulo rojo ▲ señala la posición.

17

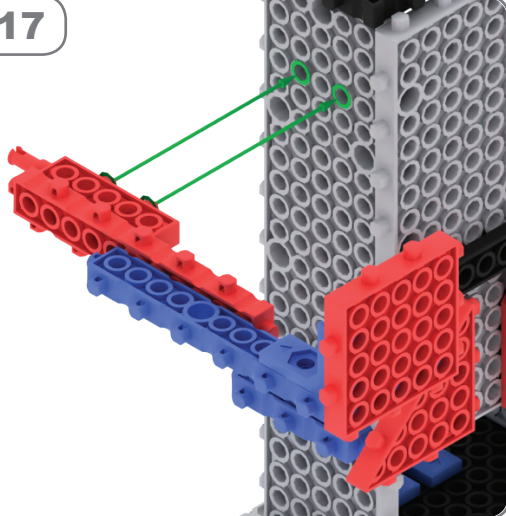

18

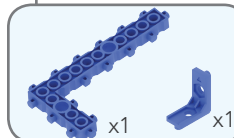
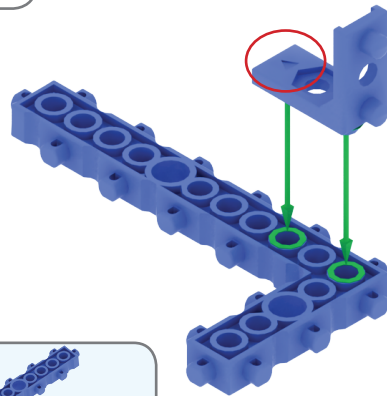

19

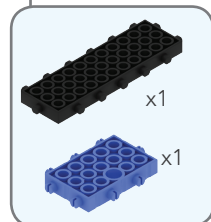
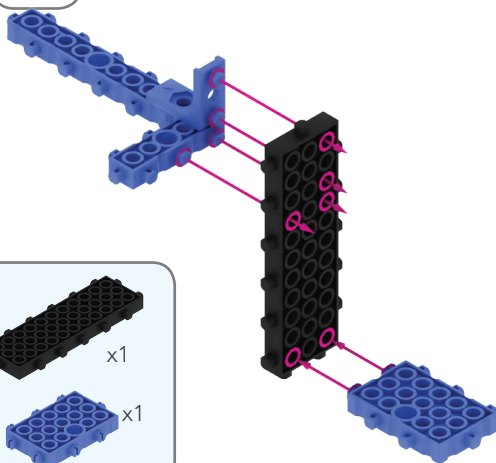

20

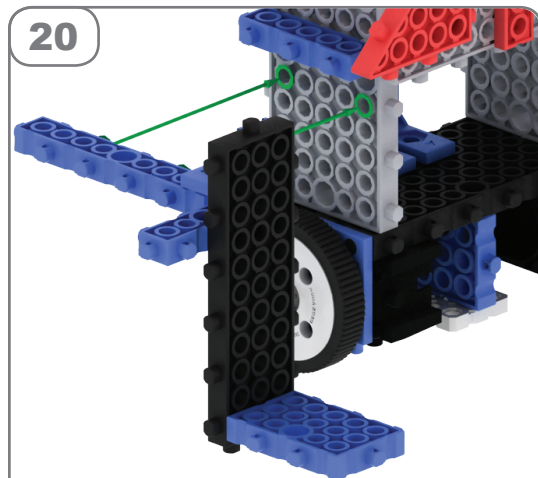

21

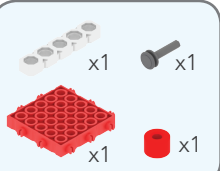
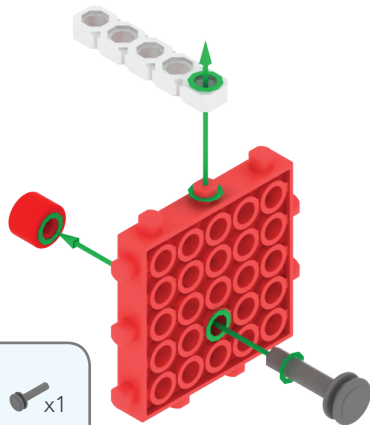

22

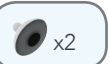
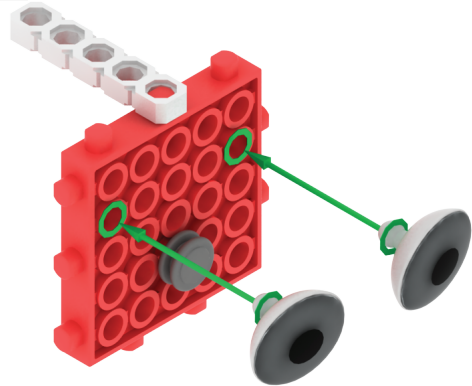

23

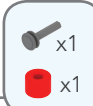
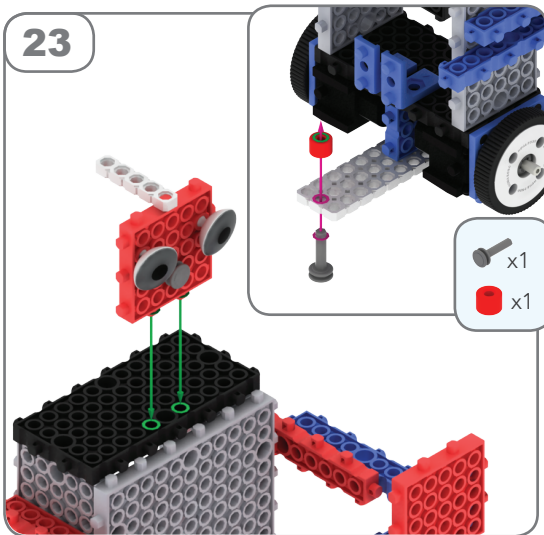

24

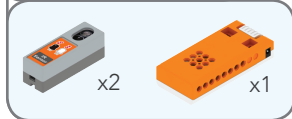
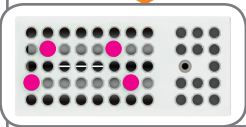
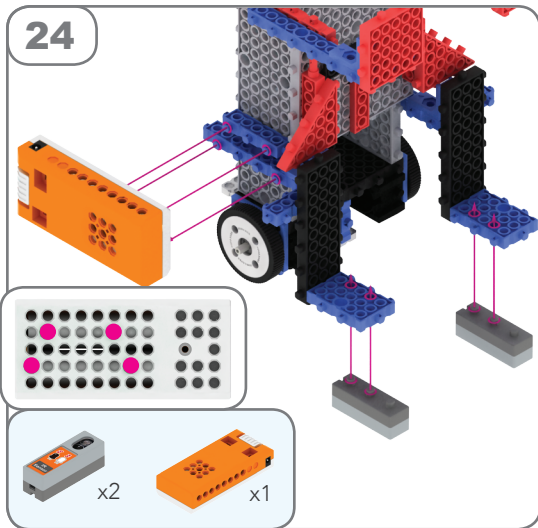

OK

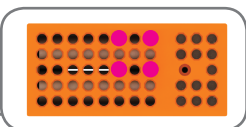
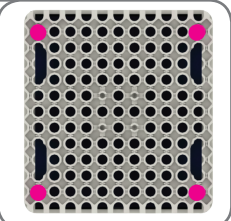
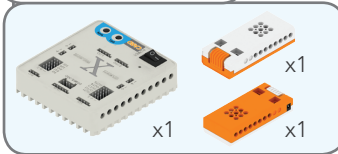
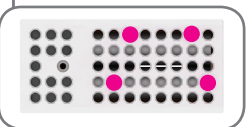
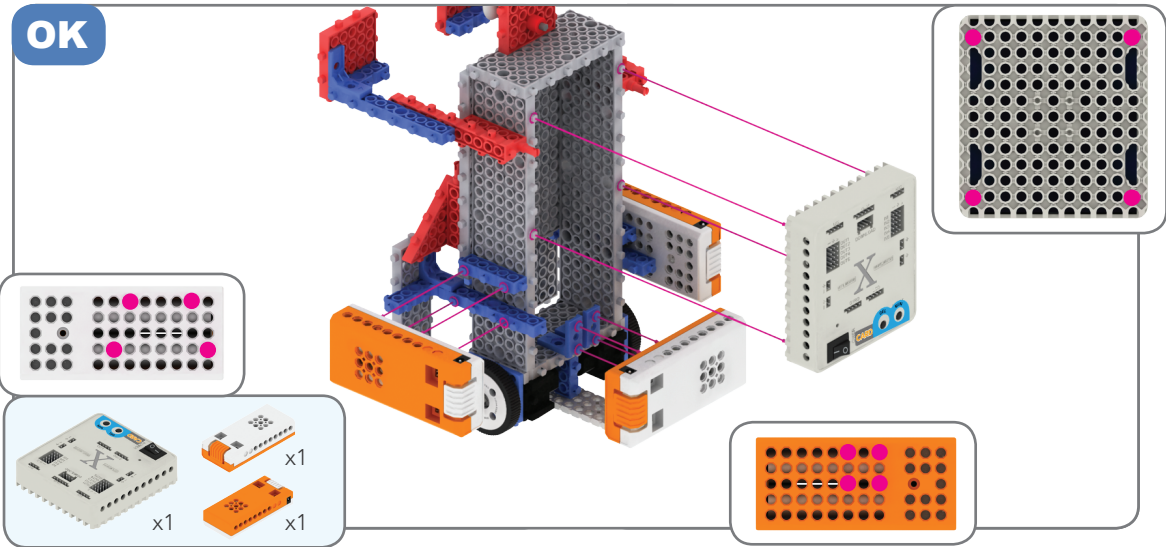

¿Cómo hacer la conexión?

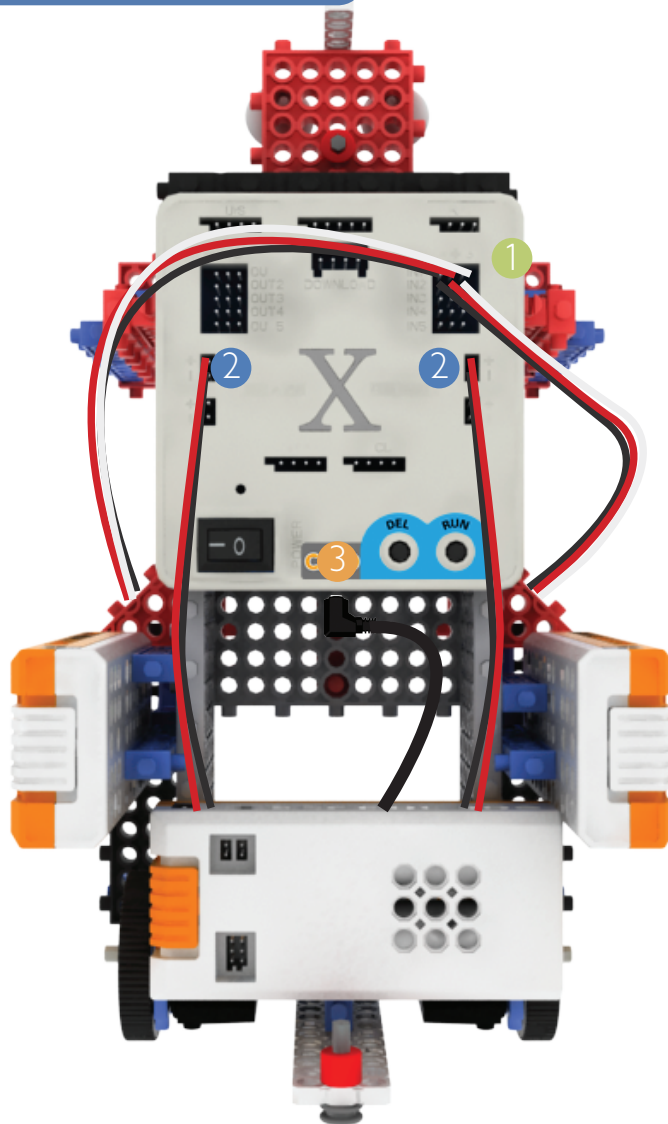

- 1 Conecta el sensor infrarrojo izquierdo en el puerto IN1 y el derecho en el puerto IN2, como se muestra arriba.
- 2 Conecta el motor a la placa base.
- 3 Conecta los portapilas con la placa base como aparece en la imagen.

Los portapilas suministrarán energía cuando se conecten a la placa con el cable de conexión negro, independientemente de la posición de sus interruptores.

Practica

Coloca el robot en el circuito.

Enciende la placa pulsando POWER, luego pulsa RUN y, después, DEL cuatro veces. La X parpadeará en color morado, entonces pulsa RUN para activar el modo 5.

El robot se pondrá en funcionamiento.

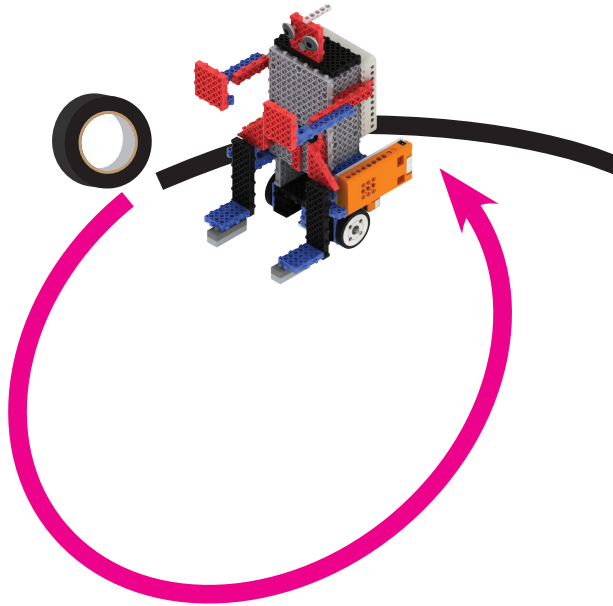

Cuando algún sensor infrarrojo detecte la línea negra, el robot volverá al circuito.

