

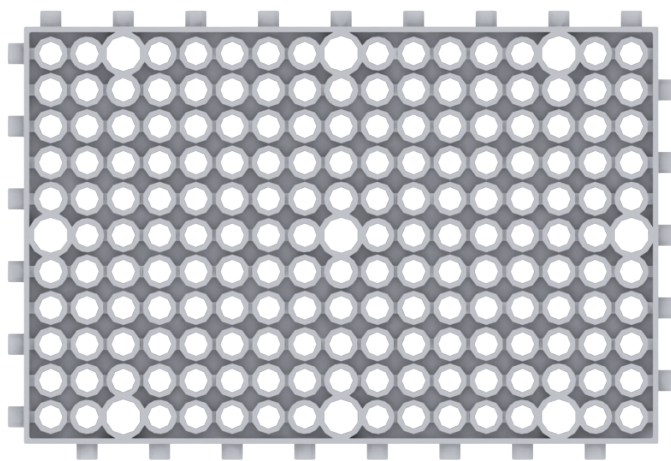

15 Locomotora



Piezas



Bloque 11x17 (1)



Adaptador L 3x4 (1)



Adaptador L 3x3 (4)



Bloque N 3x7 (2)



Bloque N 3x9 (3)



Bloque N 3x5 (1)

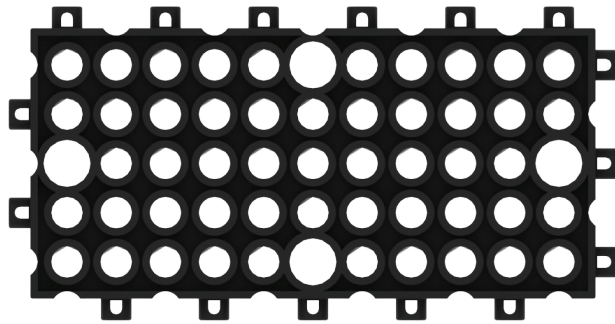

Bloque 5x11 (4)

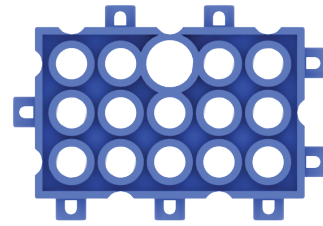

Bloque 3x5 (6)

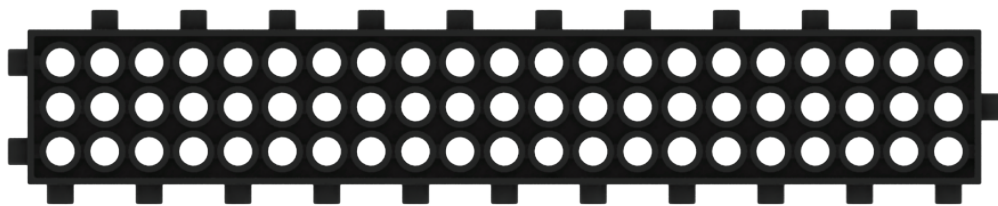

Bloque 3x21 (2)

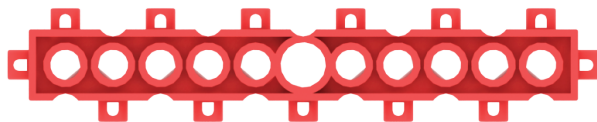

Bloque 1x11 (4)

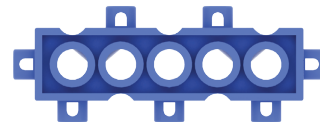

Bloque 1x5 (4)

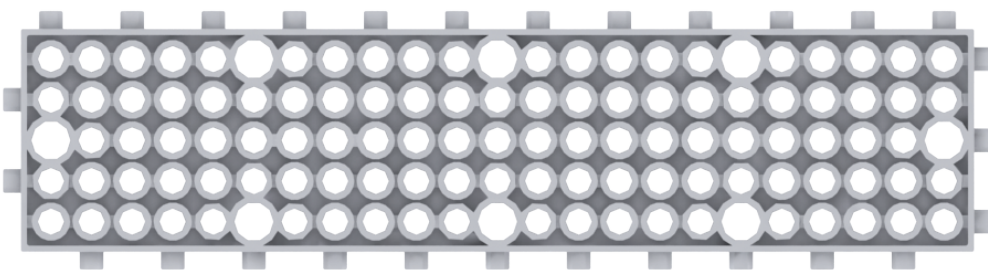

Bloque 5x23 (2)

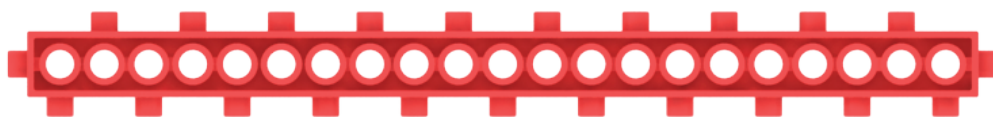

Bloque 1x21 (2)



Sensor de infrarrojos (2)



Adaptador L (4)



Goma de eje roja/
Red bush (6)



Arandela (2)



Bloque de unión 2 (2)



M-shaft

Eje M (2)



Conector de eje (2)



L-shaft

Eje L (1)

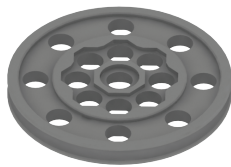

Llanta/Hub 2 (2)



Rueda polea/Guide wheel (1)



Rueda M (2)



Motor 2(2)



Engranaje S (2)



Engranaje L (2)



Cable de conexión (3)

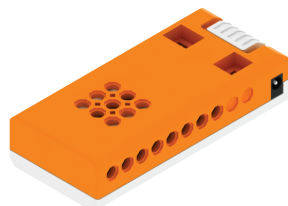

Portapilas o
portabaterías 1 (2)

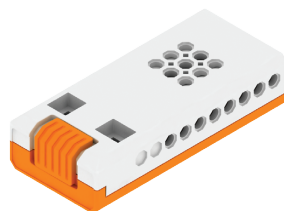

Portapilas o
portabaterías 2 (1)

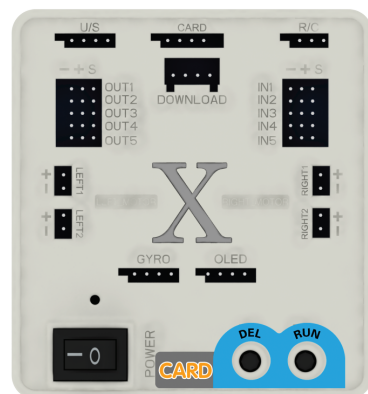

Placa base (1)

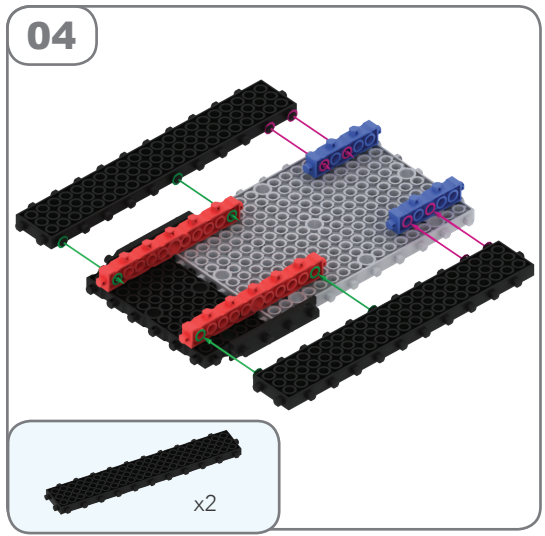
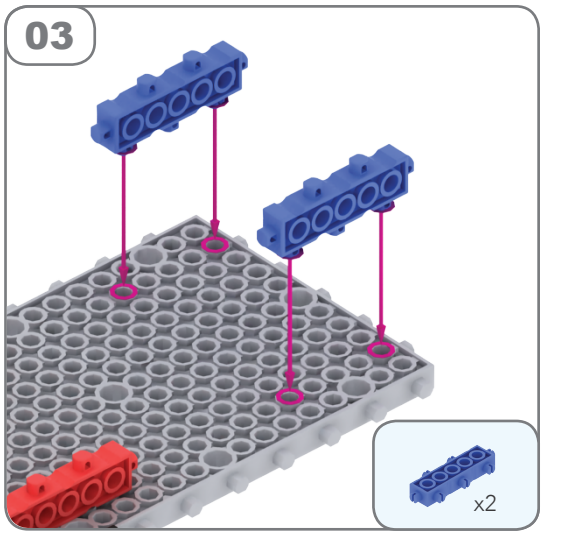
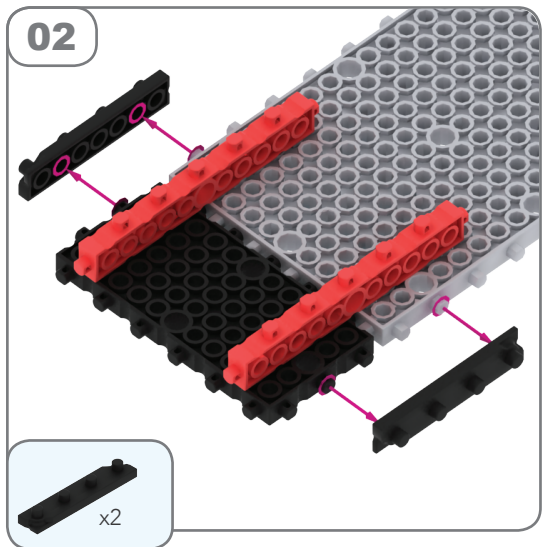
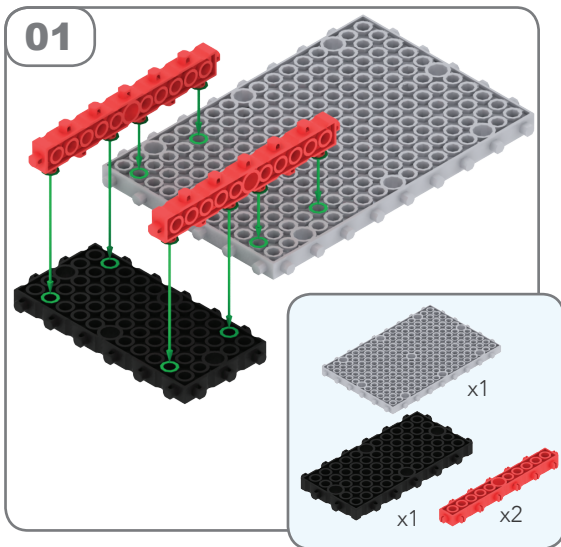

Nota: el triángulo rojo ▲ señala la posición.

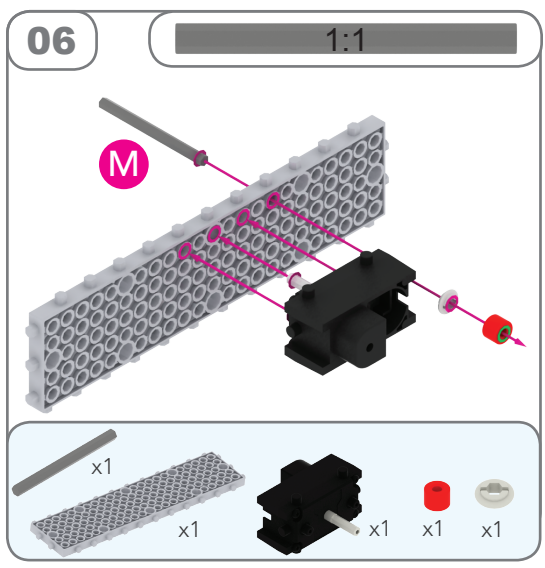
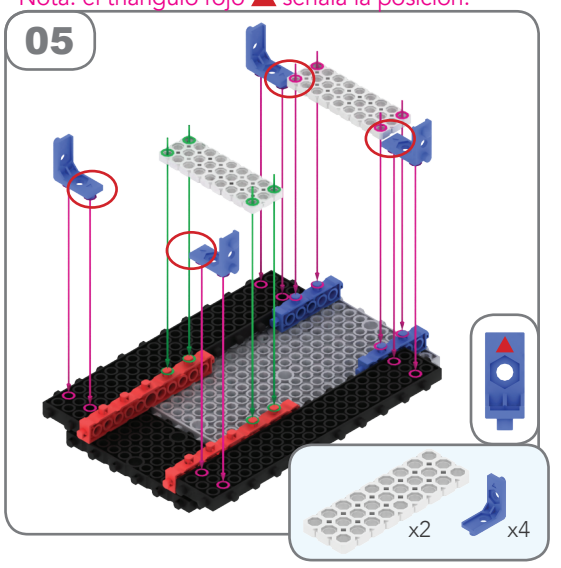

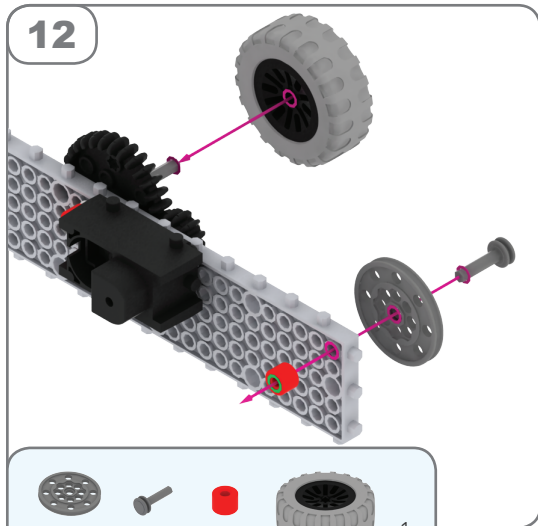
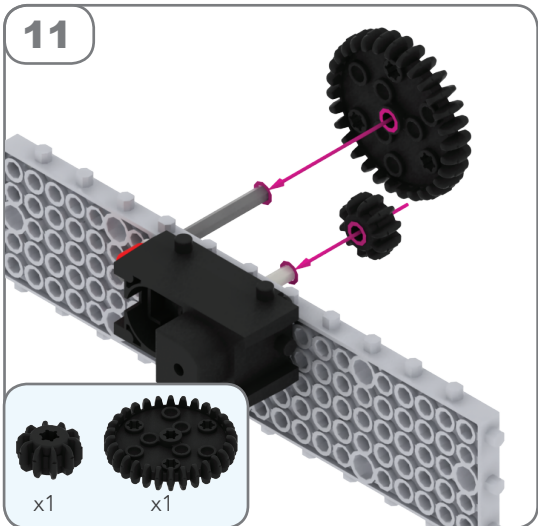
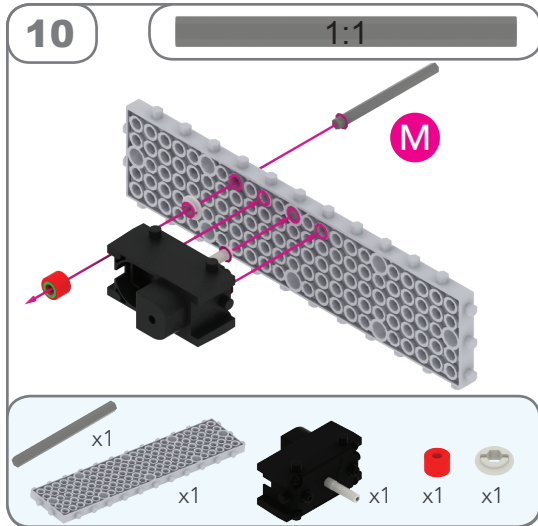
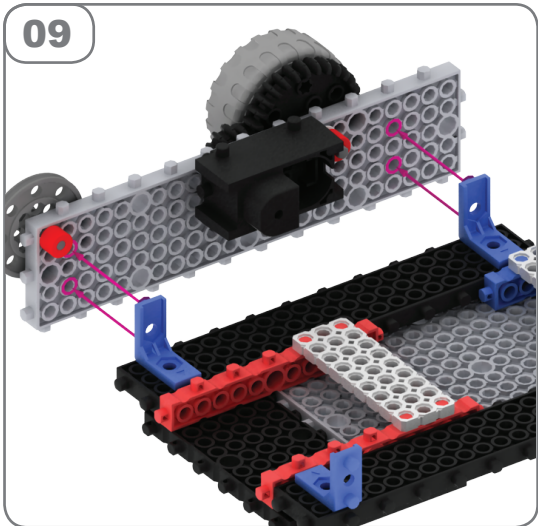
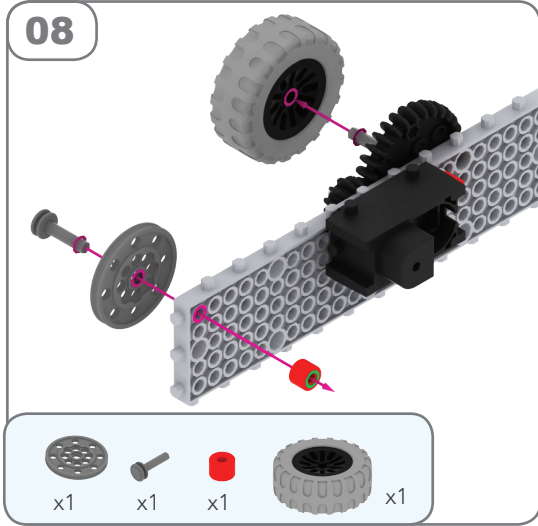
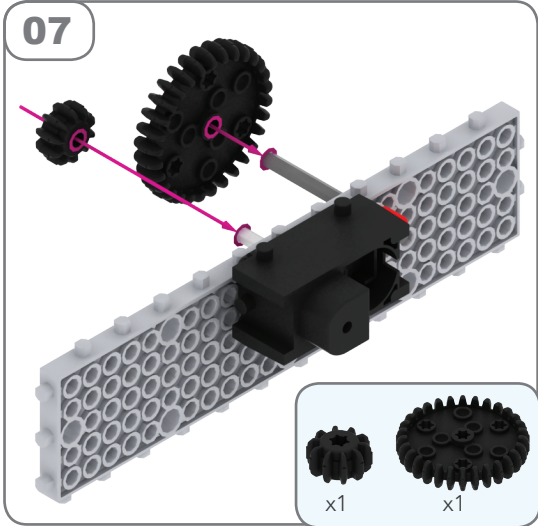

13

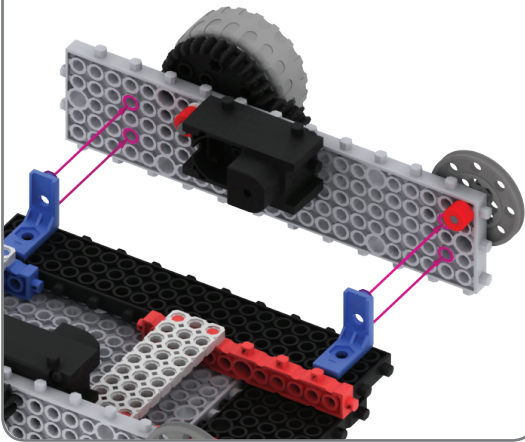

14

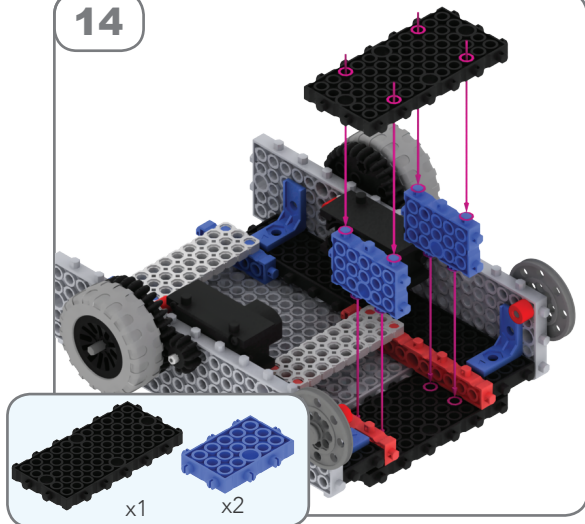

15

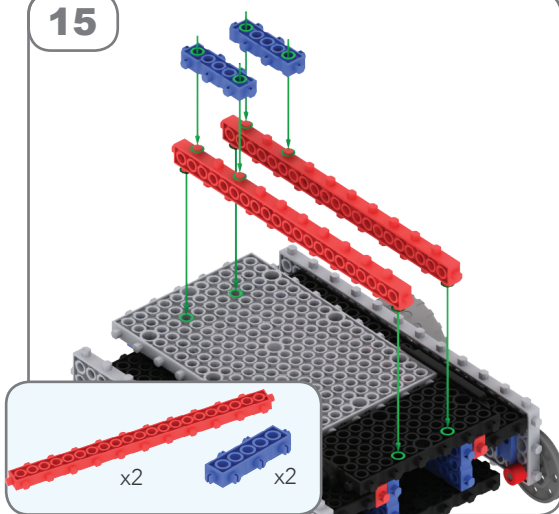

16

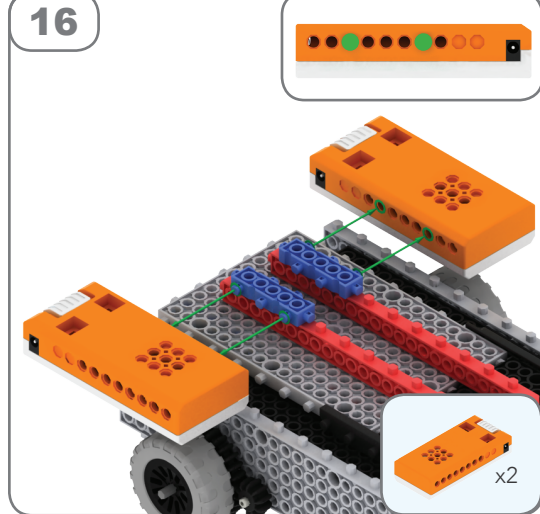

17

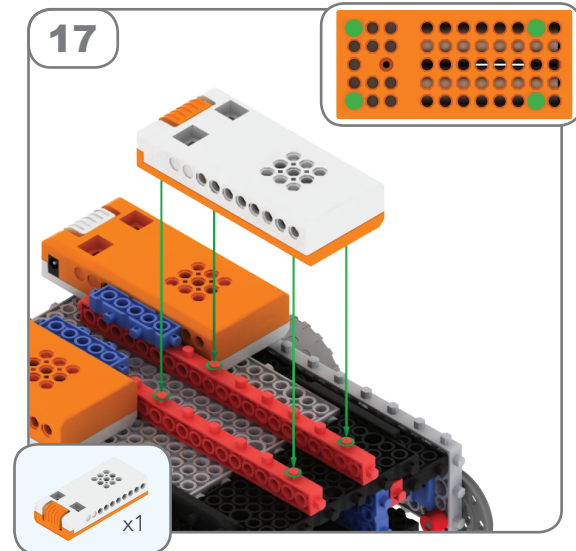

18

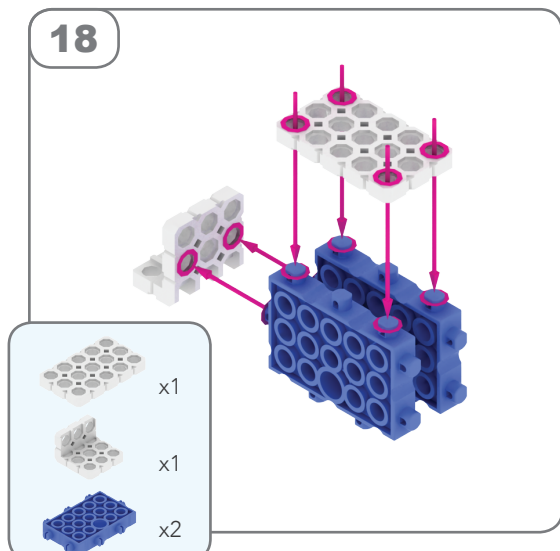

19

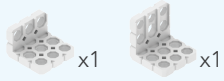
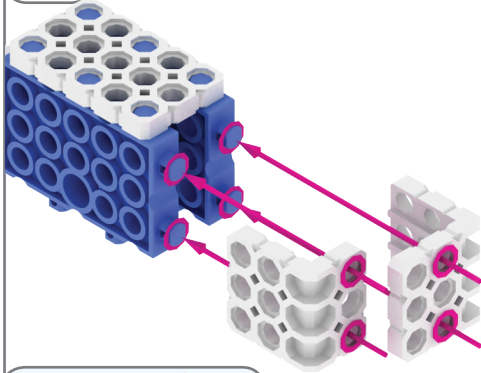

20

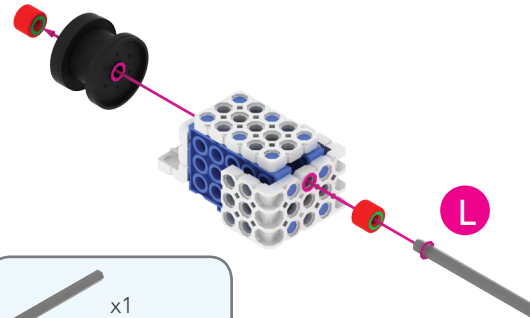

1:1

21

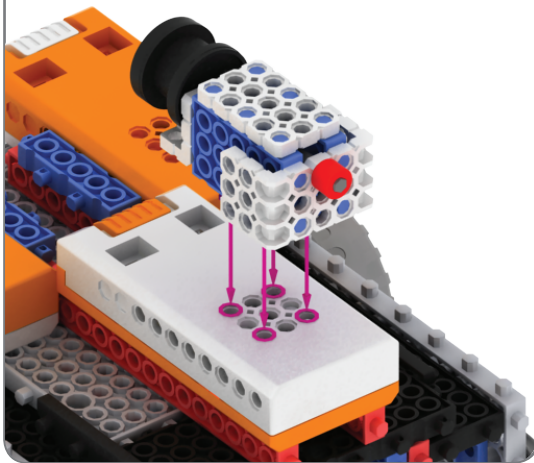

22

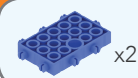
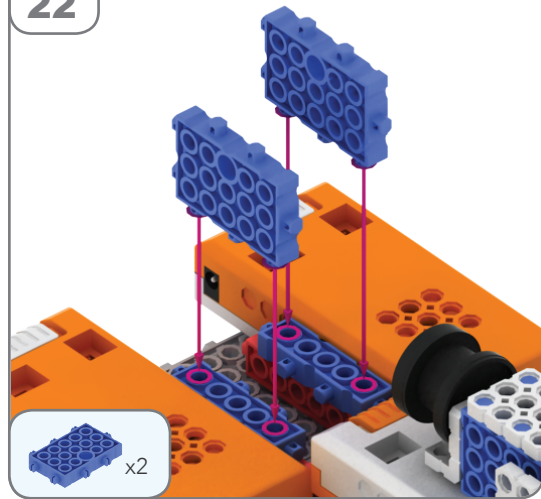

23

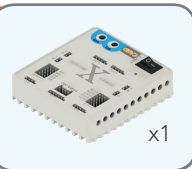
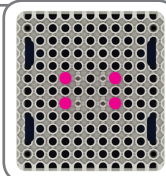
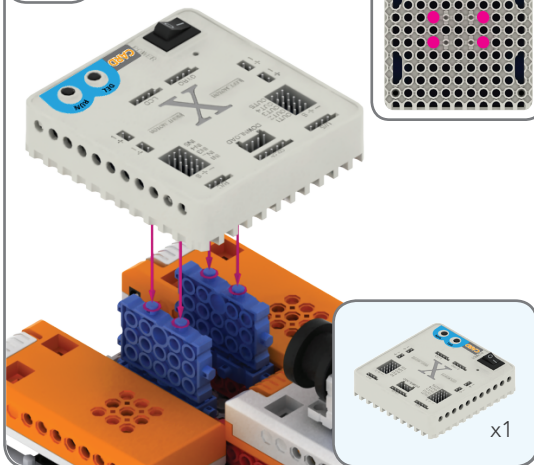

24

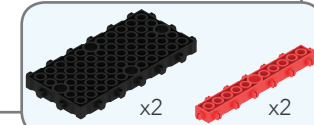
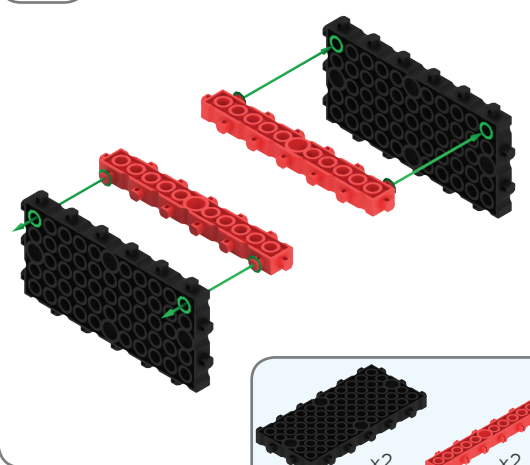

25

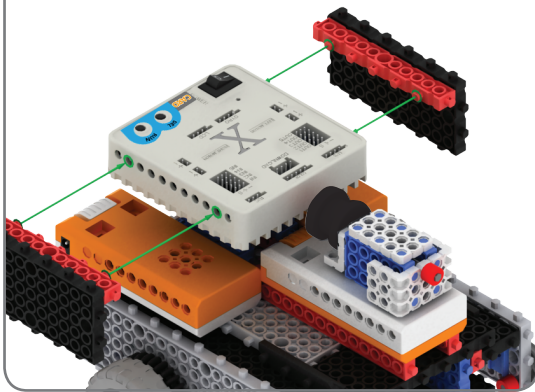

26

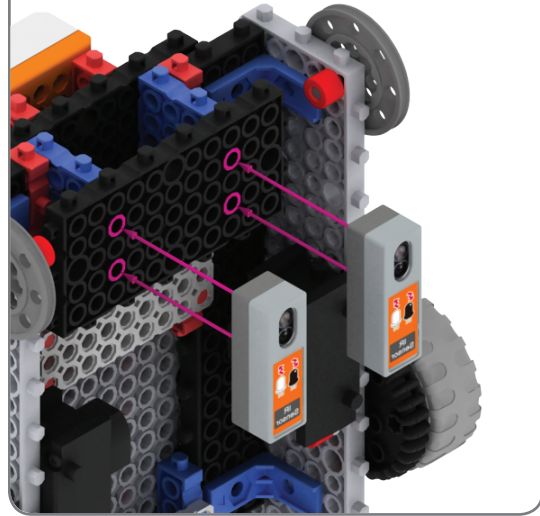
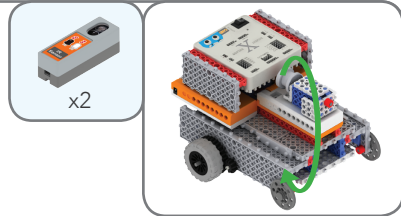

27

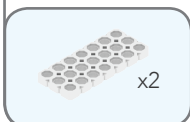
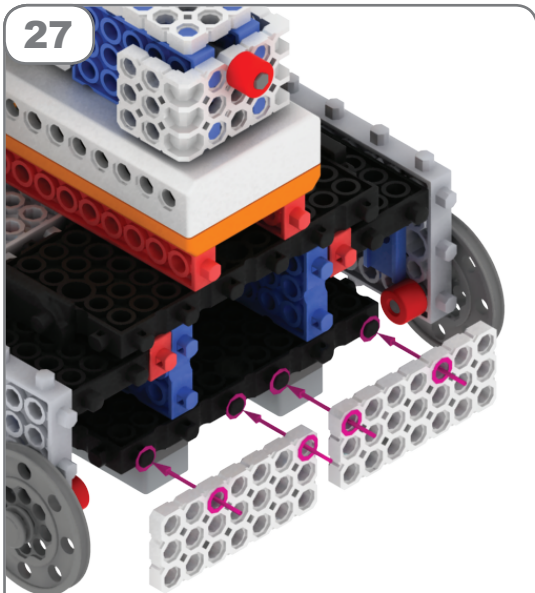

OK

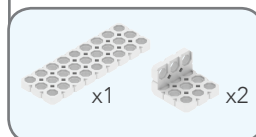
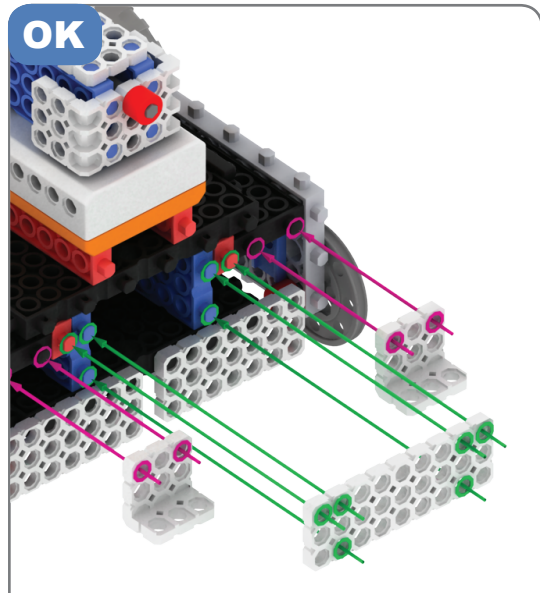

¿Cómo hacer la conexión?

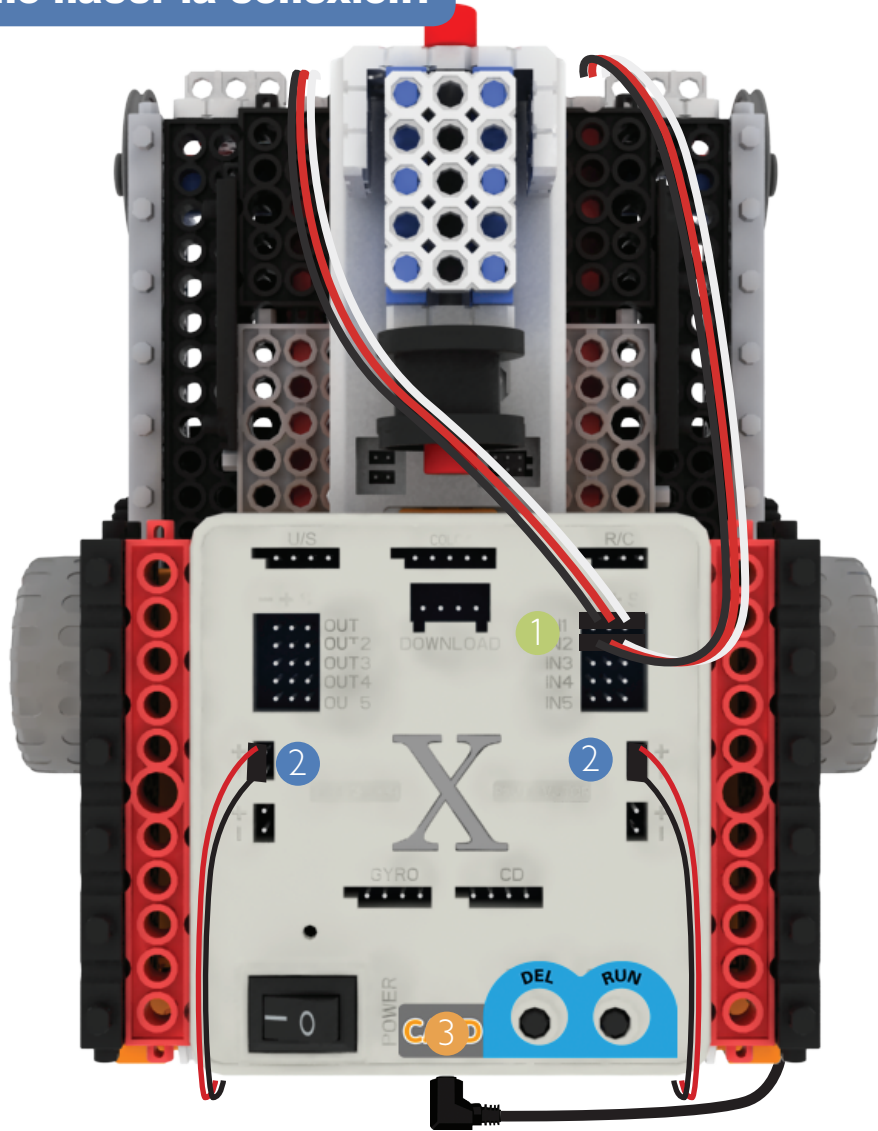

- 1 Como se muestra arriba, conecta el sensor infrarrojo izquierdo en el puerto IN1 y el derecho en el puerto IN2.
- 2 Conecta los dos motores con la placa base tal y como se muestra.
- 3 Conecta los portapilas con la placa.

Los portapilas suministrarán energía cuando se conecten a la placa con el cable negro, independientemente de la posición de sus interruptores.

Practica

Coloca la locomotora en el circuito. Debes situar la línea negra entre los dos sensores infrarrojos.

Enciende la placa pulsando POWER, luego pulsa RUN y, después, DEL tres veces. La X parpadeará en color amarillo, entonces pulsa RUN para activar el modo 4.

La locomotora se pondrá en marcha siguiendo la línea.

