

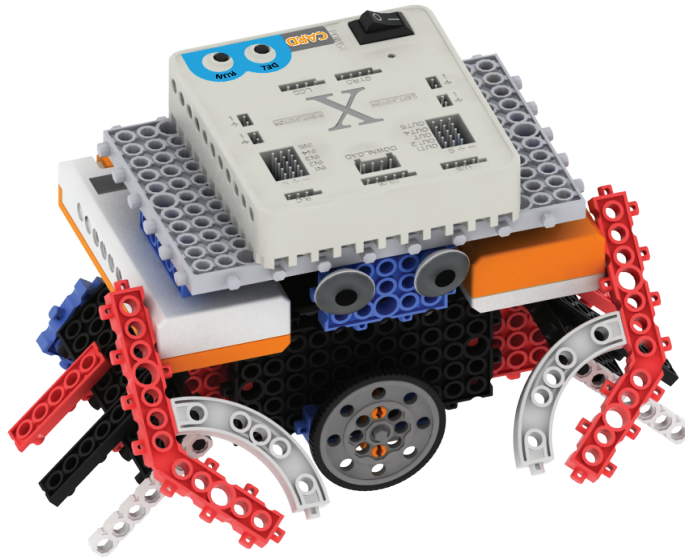

11 Cangrejo

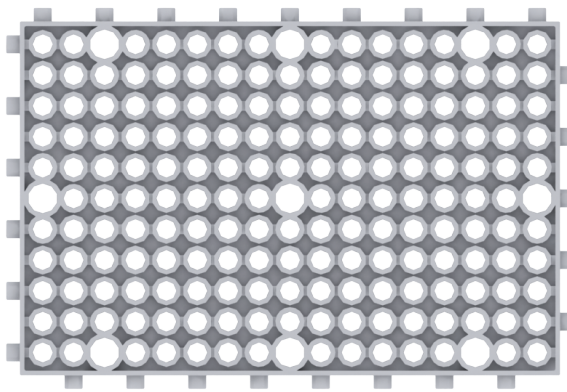

Piezas



Bloque N 11x17 (1)

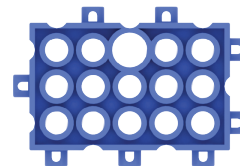

Bloque 3x5 (3)

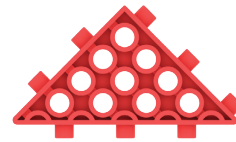

Bloque triangular (4)

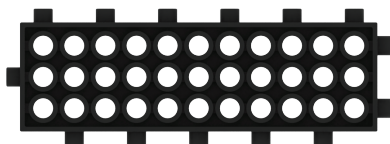

Bloque 3x11 (2)

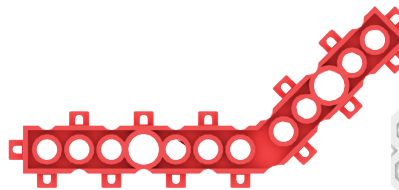

Bloque 45° (2)



Bloque N 2x5 (2)

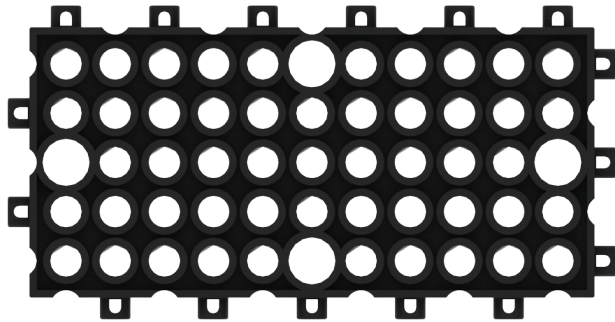

Bloque 5x11 (2)

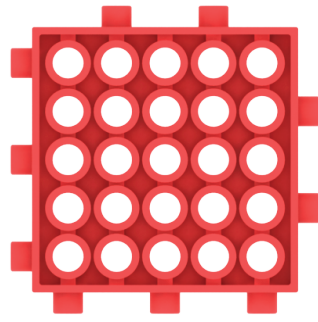

Bloque 5x5 (2)



Bloque curvo (2)

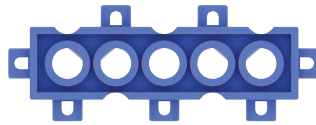

Bloque 1x5 (4)



Bloque N 1x7 (2)

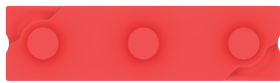

Bloque de unión 1 (4)



Bloque de unión 2 (3)



Arandela (1)



S-shaft

Eje S (1)



Unión de ejes (1)



Bloque ojo (2)



M-shaft

Eje M (1)



Cubierta/Wheel 2 (2)



Engranaje S (1)



Engranaje M (1)

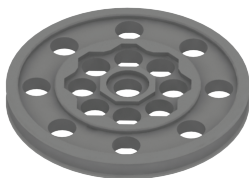

Llanta/Hub 2 (2)



Cable de conexión (2)

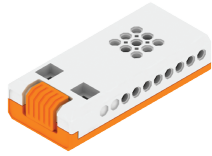

Portapilas o portabaterías 1 (1)



Motor 2 (1)

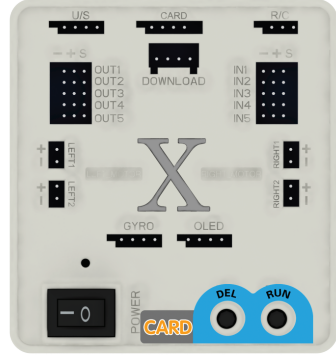

Placa base (1)

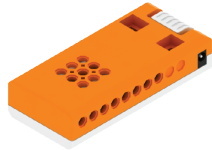

Portapilas o portabaterías 2 (1)



Remache doble tipo 1 (2)

01

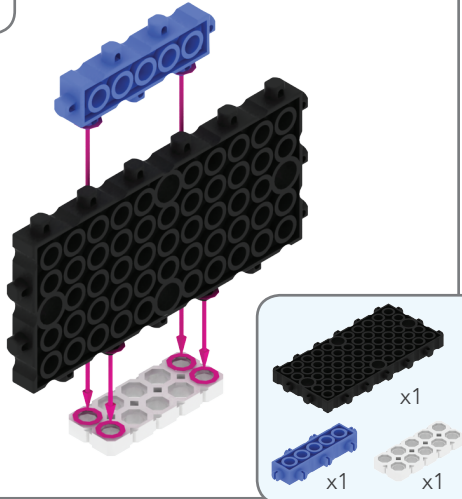

02

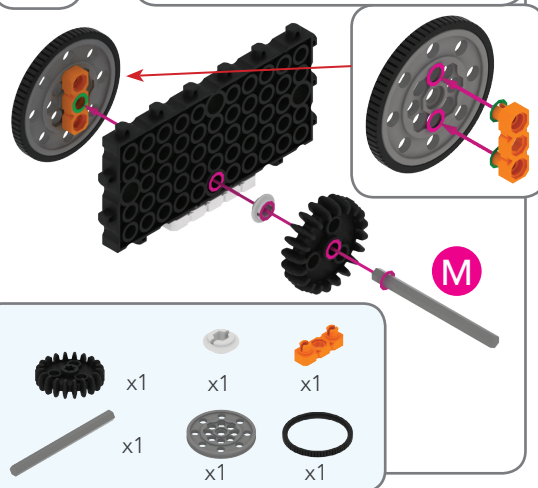

03

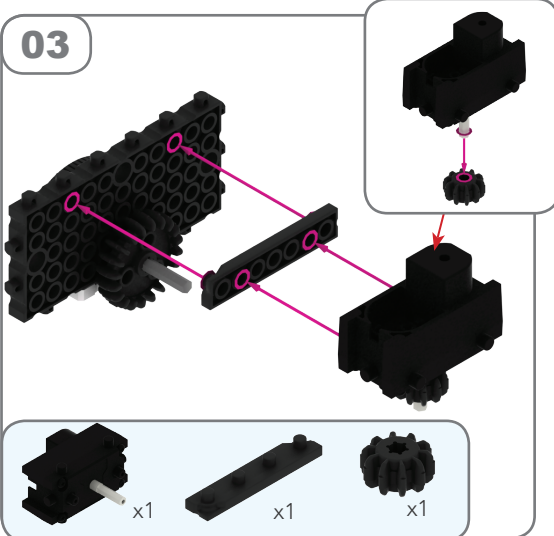

04

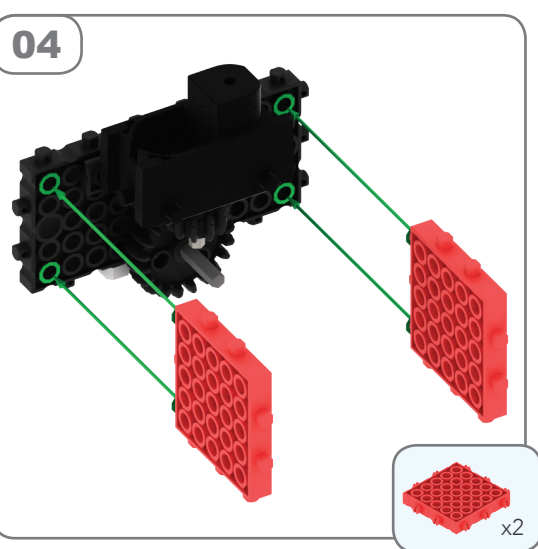

05 1:1

x1 x1

06

x1 x1 x1

07

x1 x1 x1

08

x2

09

x1 x1 x1

10

x1 x1

11

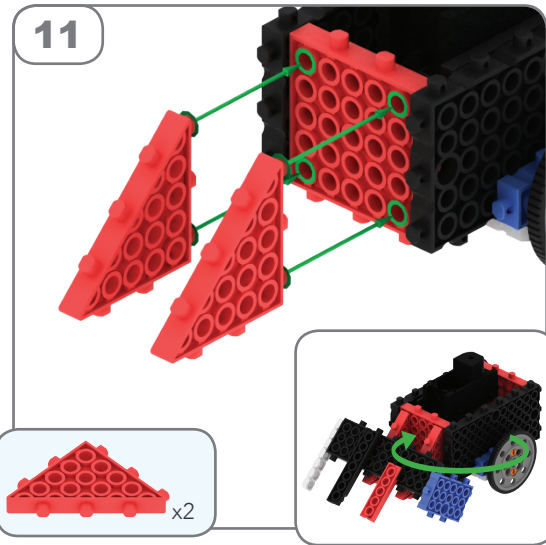

12

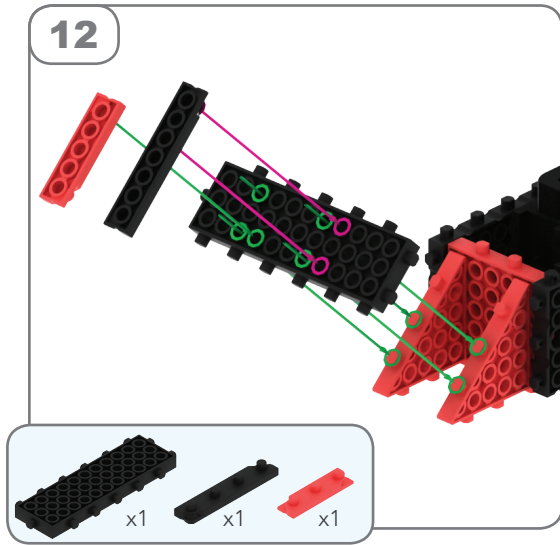

13

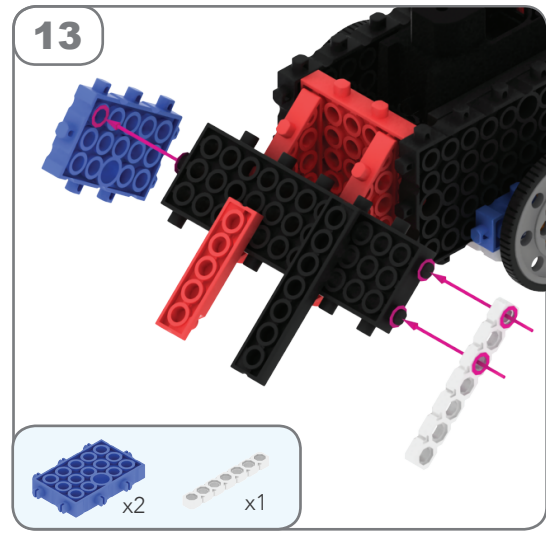

14

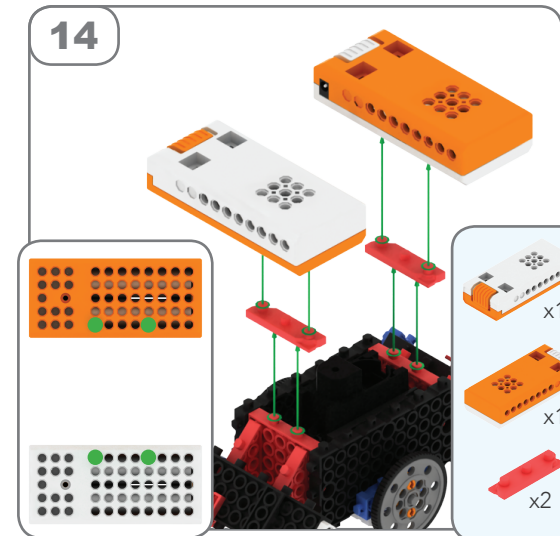

15

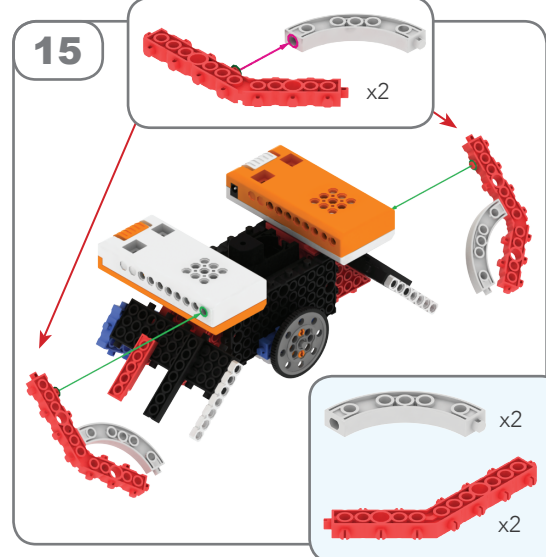

16

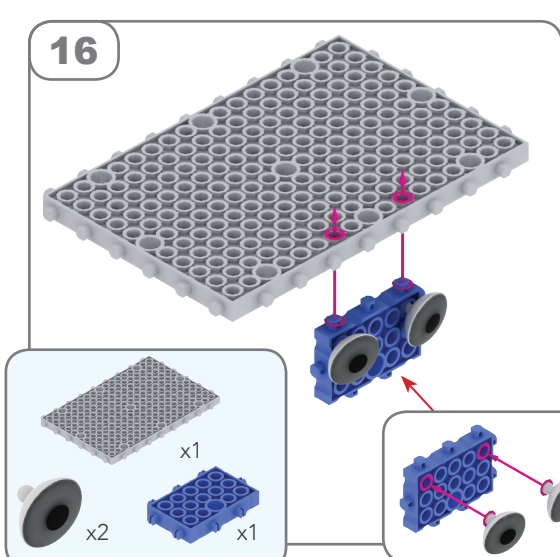

17

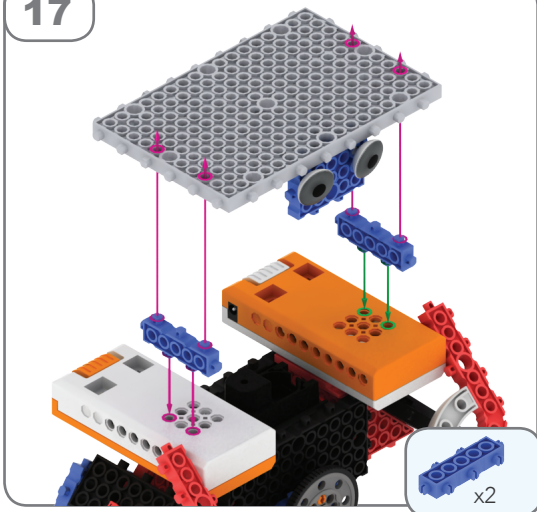

18

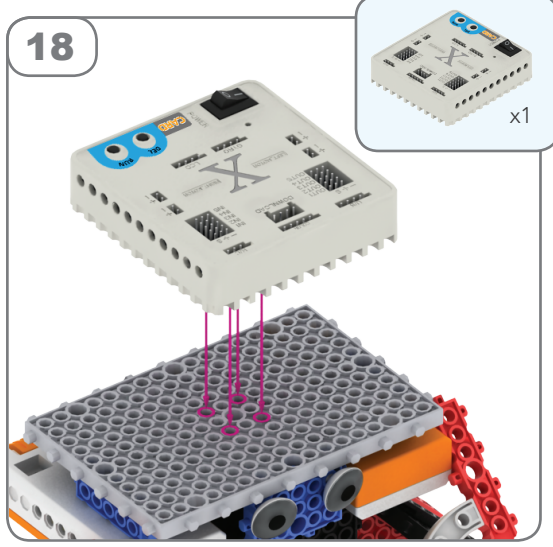

OK

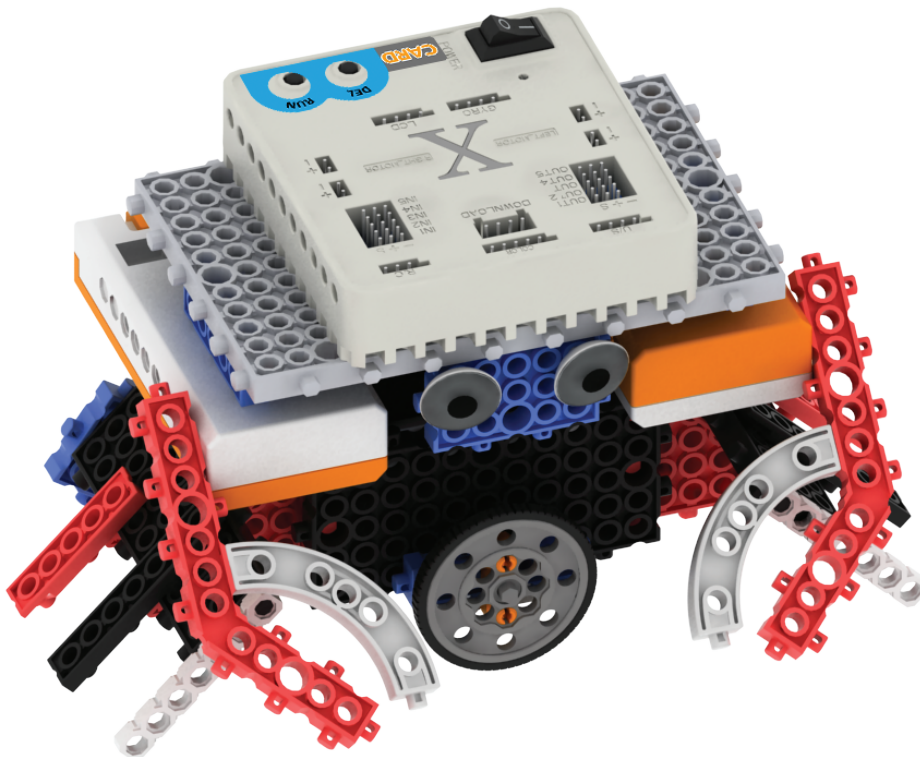

¿Cómo hacer la conexión?

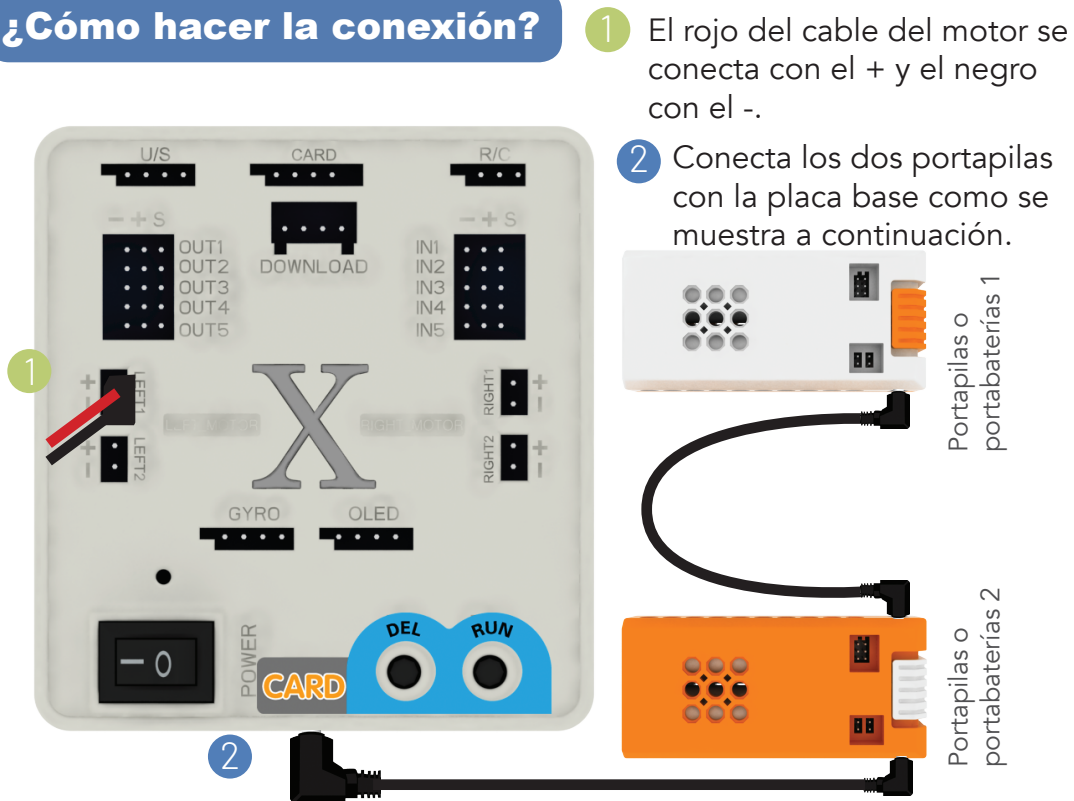

Los portapilas suministrarán energía cuando se conecten a la placa con el cable de conexión negro, independientemente de la posición de sus interruptores.

¿Cómo funciona?

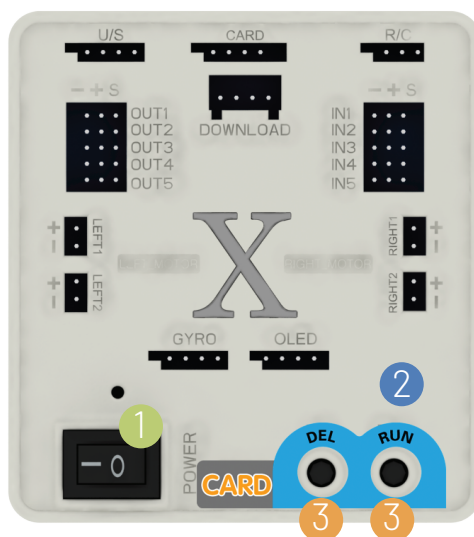

- 1 Aprieta el botón POWER para encenderlo. La X parpadeará con diferentes colores.
- 2 Presiona RUN, la luz verde parpadeará. Presiona RUN de nuevo para activar el modo 1: luz verde.
- 3 En el modo 1, DEL hace que el robot vaya hacia un lado y RUN que vaya hacia el contrario.

Practica

Cuando el cangrejo esté parado, presiona RUN para que camine hacia donde señala la flecha verde.



Presiona de nuevo RUN para que camine más rápido. ¡Tiene tres velocidades! Presiona DEL para que se detenga.

Cuando el cangrejo esté parado, presiona DEL para que camine hacia donde señala la flecha roja.



Presiona de nuevo DEL para que camine más rápido. ¡Tiene tres velocidades! Presiona RUN para que se detenga.

